

CLOUD INDUCED PV IMPACT ON VOLTAGE PROFILES FOR SMART MICROGRIDS

A THESIS

SUBMITTED TO THE DEPARTMENT OF ELECTRICAL AND
COMPUTER ENGINEERING
AND THE GRADUATE SCHOOL OF ENGINEERING AND SCIENCE
OF ABDULLAH GUL UNIVERSITY
IN PARTIAL FULFILLMENT OF THE REQUIREMENTS
FOR THE DEGREE OF
M.Sc.

By

Mustafa Ça atay KOÇER

November 2018

Mustafa
Ça atay
KOÇER

CLOUD INDUCED PV IMPACT ON VOLTAGE PROFILES

FOR SMART MICROGRIDS

AGU

2018

CLOUD INDUCED PV IMPACT ON VOLTAGE PROFILES FOR SMART MICROGRIDS

A THESIS

SUBMITTED TO THE DEPARTMENT OF ELECTRICAL AND COMPUTER
ENGINEERING

AND THE GRADUATE SCHOOL OF ENGINEERING AND SCIENCE OF
ABDULLAH GUL UNIVERSITY

IN PARTIAL FULFILLMENT OF THE REQUIREMENTS

FOR THE DEGREE OF

M.Sc.

By

Mustafa Ça atay KOÇER

November 2018

SCIENTIFIC ETHICS COMPLIANCE

I hereby declare that all information in this document has been obtained in accordance with academic rules and ethical conduct. I also declare that, as required by these rules and conduct, I have fully cited and referenced all materials and results that are not original to this work.

Name-Surname: Mustafa Ça atay KOÇER

Signature :

REGULATORY COMPLIANCE

M.Sc. thesis titled Cloud Induced PV Impact on Voltage Profiles for Smart Microgrids has been prepared in accordance with the Thesis Writing Guidelines of the Abdullah Gül University, Graduate School of Engineering & Science.

Prepared By

Advisor

Mustafa Ça atay KOÇER

Assoc. Prof. Ahmet ÖNEN

Head of the Electrical and Computer Engineering Program

Assoc. Prof. Vehbi Ça rı GÜNGÖR

ACCEPTANCE AND APPROVAL

M.Sc. thesis titled Cloud Induced PV Impact on Voltage Profiles for Smart Microgrids and prepared by Mustafa Ça atay KOÇER has been accepted by the jury in the Electrical and Computer Engineering Graduate Program at Abdullah Gül University, Graduate School of Engineering & Science.

12 / 12 / 2018

JURY:

Advisor : Assoc. Prof. Ahmet ÖNEN

Member : Prof. Ferhat DALDABAN

Member : Dr. Nurettin ÜSTKOYUNCU

APPROVAL:

The acceptance of this M.Sc. thesis has been approved by the decision of the Abdullah Gül University, Graduate School of Engineering & Science,
Executive Board dated / / and numbered

..... / /

Graduate School Dean

Prof. rfan ALAN

ABSTRACT

CLOUD INDUCED PV IMPACT ON VOLTAGE PROFILES
FOR SMART MICROGRIDS

Mustafa Ça atay KOÇER
M.Sc. in Electrical and Computer Engineering
Supervisor: Assoc. Prof. Ahmet ÖNEN

November 2018

In the history of humanity, no other invention has positively influenced everyone's life as much as the invention of electrical energy. With the electricity, the rise of civilization gained momentum, industrial technologies advanced, and scientific developments found more suitable habitat for themselves. However, in order to meet the growing demand for electricity, production costs had to be reduced. In this direction, the energy sector used fossil fuel-based solutions for cheap electricity production. However, nowadays, a tendency to use cleaner and more sustainable methods for electricity production has occurred since fossil fuel sources are limited and they increase the greenhouse gas emissions in the atmosphere. This trend brings renewable energy resources (RER) to the table as a new solution, especially in the modern electricity networks. However, since behaviors of the RERs are challenging to forecast and highly dependent on environmental factors, these resources have some severe problems in the integration into the grid, particularly in the low voltage networks, such as microgrids. In this thesis, the impact of the fluctuations in photovoltaic power (PV) generation, which happens because of frequently interrupted solar radiance by the chaotic movements of the clouds, on the load voltage levels of a real field microgrid system belonging to the Malta College of Arts Science and Technology (MCAST) campus is investigated. Also, the impact of the auxiliary sources (battery storage system and diesel generator) that are responsible for ensuring that the microgrid healthily continues its operation on the load voltage profiles is presented. The author used the MATLAB/Simulink platform for the necessary simulations and system designs.

Keywords: Photovoltaic power, microgrid, renewable energy, voltage fluctuations

ÖZET

AKILLI MİKRO EBELERİN ÇİN VOLTAJ PROFİLLERİNDE BULUT KAYNAKLI PV ETKİSİ

Mustafa Çağrı KOÇER

Elektrik ve Bilgisayar Mühendisliği Bölümü Yüksek Lisans

Tez Yöneticisi: Doç. Dr. Ahmet ÖNEN

Kasım-2018

İnsanlık tarihinde, elektrik enerjisinin icadının etkilediği kadar, herkesin yaşamını olumlu bir şekilde etkileyen başka bir buluş yoktur. Elektrik ile birlikte, medeniyetin yükselişi hız kazandı, endüstriyel teknolojiler gelişti ve bilimsel gelişmeler kendilerine daha uygun bir ortam buldu. Ancak, artan elektrik talebini karşılayabilmek için üretim maliyetlerinin düşürülmesi gerekiyordu. Bu doğrultuda, enerji sektörü ucuz elektrik üretimi için fosil yakıt bazlı çözümler kullandı. Ancak günümüzde, fosil yakıt kaynakları sınırlı oldukları için ve atmosferdeki sera gazı emisyonunu artırdıklarından, elektrik üretimi için daha temiz ve daha sürdürülebilir yöntemler kullanmaya yönelik bir eğilim oluştu. Bu trend, özellikle modern elektrik ebekeleri için, yenilenebilir enerji kaynaklarını (YEK) yeni bir çözüm olarak masaya getirmektedir. Bununla birlikte, YEK'lerin davranışları tahmin edilmesi zor ve çevresel etkenlere bağlı derecede belirsiz olduğu için, özellikle mikro ebekeler gibi alçak gerilim ebekelerinde, bu kaynakların ebeye entegrasyonunda bazı ciddi sorunlarla karşılaşmaktadır. Bu tezde, bulutların kaotik hareketleri ile sık sık kesintiye uğrayan güneş ışınlarından kaynaklanan, fotovoltajik güç üretimindeki dalgalanmaların, Malta College of Arts Science and Technology (MCAST) kampüsüne ait olan bir gerçek mikro ebekesi sisteminin yük voltajı seviyeleri üzerine olan etkisi araştırılmıştır. Ek olarak, mikro ebekenin sağlıklı bir şekilde çalışmaya devam etmesini sağlamaktan sorumlu olan yardımcı kaynakların (batarya depolama sistemi ve dizel jeneratör) yük voltaj profillerine olan etkisi de verilmektedir. Yazar, gerekli simülasyonlar ve sistem tasarımları için MATLAB/Simulink platformunu kullanmıştır.

Anahtar kelimeler: Fotovoltajik güç, mikroşebeke, yenilenebilir enerji, voltaj dalgalanmaları

Acknowledgements

Firstly, I would like to thank my research advisor Associate Professor Ahmet ÖNEN. His office was always open whenever I had a problem or needed advice about my research. Especially, I am so grateful for his endless support and wise advice on my career plans.

I would also like to thank Burhan KABATA , who is an excellent example of professionalism, for facilitating every challenge I encountered.

I am so grateful to my dear friends Esra SÜMER, Rukiye Nur KAÇMAZ and Gizem GÖRÜR who always support me and share our wonderful times. I have had one of the most fun and quality times of my life with them in the last two years.

I am particularly grateful to Bengisu SOYKUVVET, who makes invaluable contributions to my life and has the most significant share in every success I have achieved so far.

Finally, I must express my deep gratitude to my dear family for providing me with endless support and continuous encouragement. Nothing would have been possible without them. Thank you so much.

Table of Contents

1. INTRODUCTION	1
1.1 GLOBAL PV MARKET	2
1.2 PV POWER INTEGRATION INTO THE GRID	5
1.3 LITERATURE REVIEW	7
1.4 THESIS SCOPE	11
1.5 OVERVIEW OF THE THESIS	12
2. MICROGRID.....	14
2.1 NEW CONCEPT: MICROGRID	15
2.1.1 <i>Types of Microgrids</i>	16
2.1.1.1 <i>Campus Microgrids</i>	16
2.1.1.2 <i>Remote “Off-grid” Microgrids</i>	17
2.1.1.3 <i>Commercial and Industrial (C&I) Microgrids</i>	17
2.1.1.4 <i>Military Base Microgrids</i>	17
2.1.2 <i>Architecture of Microgrid</i>	17
2.1.2.1 <i>Distributed Generation (DG)</i>	19
2.1.2.2 <i>Energy Storage Devices</i>	19
2.1.2.3 <i>Loads</i>	19
2.1.2.4 <i>Control and Communication Systems</i>	20
2.1.2.5 <i>Point of common coupling (PCC)</i>	20
2.1.3 <i>Operation and Control of Microgrid</i>	21
2.1.3.1 <i>Centralized Control</i>	22
2.1.3.2 <i>Decentralized Control</i>	23
2.1.4 <i>Benefits and Challenges of Microgrid</i>	23
3. 3DMICROGRID.....	26
3.1 OBJECTIVES OF 3DMICROGRID	27
3.2 BENEFITS AND NOVELTY OF 3DMICROGRID	27
3.3 3DMICROGRID ARCHITECTURE.....	28
3.3.1 <i>Grid & Market Services</i>	29
3.3.2 <i>Tertiary Control Platform</i>	29
3.3.2.1 <i>On-Grid Manager</i>	29
3.3.2.2 <i>Dispatch Optimization</i>	30
3.3.3 <i>Centralized Controller (Secondary Control Platform)</i>	30
3.3.3.1 <i>Off-Grid Manager (Islanding Mode)</i>	30
3.3.3.2 <i>Transition Control</i>	30
3.3.3.3 <i>Agent Balance</i>	31
3.3.4 <i>Agents – Local Controllers (Primary Control Agents)</i>	31
3.3.5 <i>Demand & Generation Forecasting (DGF)</i>	31
3.3.6 <i>Multi-Sensorial Network</i>	32
3.3.7 <i>SCADA Human-Machine Interaction (HMI)</i>	32
3.3.8 <i>3DMicroGrid Repository</i>	32
3.3.9 <i>Simulation Platform (MATLAB/Simulink)</i>	32
4. SIMULATION RESULTS	38
4.1 OPERATION SCENARIO OF 3DMICROGRID	38
4.2 CLOUD INDUCED PV IMPACT ON VOLTAGE PROFILES	38
4.3 CASE STUDIES AND RESULTS	39
4.3.1 <i>Base Case: Full Cloudy without BSS</i>	40

4.3.2 Case 2: Full Cloudy with BSS	44
4.3.3 Case 3.....	48
4.3.3.1 Case 3: 80% PV Penetration.....	48
4.3.3.2 Case 3: 60% PV Penetration.....	55
4.3.3.3 Case 3: 40% PV Penetration.....	62
4.3.3.4 Case 3: 20% PV Penetration.....	69
4.4 VOLTAGE DROPS FOR ALL CASES.....	76
5. CONCLUSIONS AND FUTURE WORKS.....	77
5.1 CONCLUSIONS	77
5.2 FUTURE WORKS	78
6. BIBLIOGRAPHY	80

List of Figures

Figure 1.1.1 Evolution of Annual PV Installations (GW-DC)	2
Figure 1.1.2 Evolution of PV Installations (GW-DC)	4
Figure 1.2.1 Grid challenges on different timescales	6
Figure 2.1.2.1 Simple microgrid architecture	18
Figure 3.3.1 3DMicroGrid system architecture	28
Figure 3.3.9.1 3DMicroGrid MATLAB/Simulink model	33
Figure 3.3.9.2 3DMicroGrid MATLAB/Simulink building model - controllable and uncontrollable loads	33
Figure 3.3.9.3 3DMicroGrid MATLAB/Simulink PV system model	34
Figure 3.3.9.4 3DMicroGrid MATLAB/Simulink battery storage system (BSS) model	34
Figure 3.3.9.5 3DMicroGrid MATLAB/Simulink diesel generator model	35
Figure 3.3.9.6 3DMicroGrid MATLAB/Simulink underground cable model ...	35
Figure 3.3.9.7 The electrical network plan of the 3DMicroGrid	36
Figure 4.3.1.1 Voltage graph of Building D without BSS for the base case	40
Figure 4.3.1.2 Voltage graph of Building F without BSS for the base case	41
Figure 4.3.1.3 Voltage graph of Building J without BSS for the base case	42
Figure 4.3.1.4 Voltage drops in buildings for the base case	43
Figure 4.3.2.1 Voltage graph of Building D with BSS for case 2	44
Figure 4.3.2.2 Voltage graph of Building F with BSS for case 2	45
Figure 4.3.2.3 Voltage graph of Building J with BSS for case 2	46
Figure 4.3.2.4 Voltage drops in buildings for the case 2	47

Figure 4.3.3.1.1 80% PV Penetration voltage graph of Building D without BSS	48
Figure 4.3.3.1.2 80% PV Penetration voltage graph of Building F without BSS	49
Figure 4.3.3.1.3 80% PV Penetration voltage graph of Building J without BSS	50
Figure 4.3.3.1.4 80% PV Penetration voltage graph of Building D with BSS ...	51
Figure 4.3.3.1.5 80% PV Penetration voltage graph of Building F with BSS	52
Figure 4.3.3.1.6 80% PV Penetration voltage graph of Building J with BSS	53
Figure 4.3.3.1.7 Voltage drops in buildings for the 80% penetration level	54
Figure 4.3.3.2.1 60% PV Penetration voltage graph of Building D without BSS.	55
Figure 4.3.3.2.2 60% PV Penetration voltage graph of Building F without BSS.	56
Figure 4.3.3.2.3 60% PV Penetration voltage graph of Building J without BSS.	57
Figure 4.3.3.2.4 60% PV Penetration voltage graph of Building D with BSS ...	58
Figure 4.3.3.2.5 60% PV Penetration voltage graph of Building F with BSS	59
Figure 4.3.3.2.6 60% PV Penetration voltage graph of Building J with BSS	60
Figure 4.3.3.2.7 Voltage drops in buildings for the 60% penetration level	61
Figure 4.3.3.3.1 40% PV Penetration voltage graph of Building D without BSS.	62
Figure 4.3.3.3.2 40% PV Penetration voltage graph of Building F without BSS.	63
Figure 4.3.3.3.3 40% PV Penetration voltage graph of Building J without BSS.	64
Figure 4.3.3.3.4 40% PV Penetration voltage graph of Building D with BSS ...	65
Figure 4.3.3.3.5 40% PV Penetration voltage graph of Building F with BSS	66
Figure 4.3.3.3.6 40% PV Penetration voltage graph of Building J with BSS	67
Figure 4.3.3.3.7 Voltage drops in buildings for the 40% penetration level	68

Figure 4.3.3.4.1 20% PV Penetration voltage graph of Building D without BSS.	69
Figure 4.3.3.4.2 20% PV Penetration voltage graph of Building F without BSS.	70
Figure 4.3.3.4.3 20% PV Penetration voltage graph of Building J without BSS.	71
Figure 4.3.3.4.4 20% PV Penetration voltage graph of Building D with BSS ...	72
Figure 4.3.3.4.5 20% PV Penetration voltage graph of Building F with BSS....	73
Figure 4.3.3.4.6 20% PV Penetration voltage graph of Building J with BSS	74
Figure 4.3.3.4.7 Voltage drops in buildings for the 20% penetration level	75

List of Tables

Table 1.1.1 Top 10 Countries for Installations and Total Installed Capacity in 2016.	3
Table 2.1.2.1 Microgrid examples in Europe	21
Table 3.3.9.1 Assets and loads of all buildings in 3DMicroGrid	37
Table 4.4.1 Voltage drops in buildings for all cases.....	76

*To Mustafa Kemal ATATÜRK
and heroes of Turkish War of Independence*

Chapter 1

Introduction

Ever since the big bang, energy is widely considered to be the essential component of our universe. Not only living creatures, but even stars also need energy during their formation process. Although we live in a universe where energy is so necessary, unfortunately, we have not yet discovered or produced a perfect solution to address this issue. Despite recent developments in technology, until now, humanity has not yet reached the depths of space, and this situation pushes us to try to solve our problems using the resources on this planet and this solar system. In this direction, every living species evolved peculiarly to overcome this problem. In order to gain the amount of energy enough to survive, plants became able to photosynthesize using the most significant energy source of our solar system, animals formed a feeding-based system, besides all these, humankind developed many different methods to collect energy not only to survive but also to increase the quality of their lives and as an undeniable fact, electricity is the most special one among these solutions. However, as human beings diversify ways to meet their energy needs, problems that human face, also, have varied and got harder to solve.

Climate change is the most striking of these problems. This critical problem, which slowly sets our planet's end, is already among the most significant problems encountered in planetary history. More importantly, the primary cause of this prominent issue is the greenhouse gas emission that fossil fuels have produced, according to the recent researches so far. Even though it helps us to solve most of our daily problems and ease our daily lives such as transportation, heating, etc. the damage that fossil fuels give directly or indirectly to our planet is moving rapidly towards the unrecoverable stage. To reduce the destructive

effects of fossil fuels, a lot of significant studies are being carried out on a full scale from around the world, from scientific researches to legal arrangements. All these studies show us that sustainable renewable energy is the only answer we have at the moment to all the major energy and pollution problems we have faced.

Decreasing cost ratios of renewable energy types over the years and the increase in the efficiency rates allow these methods to be used more. Especially with the increasing number of projects in recent years, solar photovoltaic power is the most prominent one among renewable energy types and the next decades are likely to witness a considerable rise in photovoltaic power (PV).

1.1 Global PV Market

With the influence of global policies, it is possible to see an exponential graph increasing every year in countries' solar energy investments.

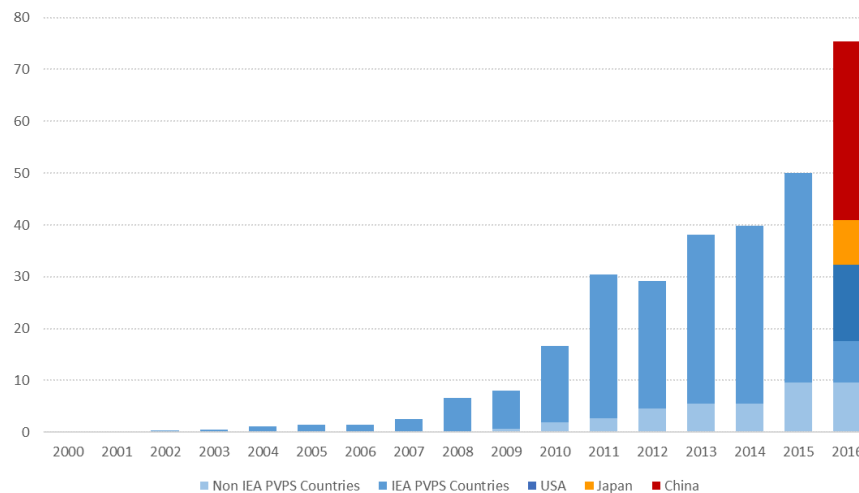

Figure 1.1.1 Evolution of Annual PV Installations (GW-DC) [1]

Looking at recent years, the year 2014 is the year in which the solar energy industry's growth rate is the lowest, but the market successfully reversed the negative impact of 2014 with 25% and 50% growth rates caught in 2015 and

2016 respectively and the year 2016 has been the year of the greatest growth in the market since 2011. Figure 1.1.1 shows the increase in PV investments [1].

RANK	COUNTRIES	IN 2016 FOR ANNUAL INSTALLED CAPACITY	IN 2016 FOR CUMULATIVE INSTALLED CAPACITY
1	China	35,5 GW	78,1 GW
2	USA	14,7 GW	42,8 GW
3	Japan	8,6 GW	41,2 GW
4	India	4 GW	40,3 GW
5	UK	2 GW	19,3 GW
6	Germany	1,5 GW	11,6 GW
7	Korea	0,9 GW	9 GW
8	Australia	0,8 GW	7,1 GW
9	Philippines	0,8 GW	5,9 GW
10	Chile	0,7 GW	5,5 GW

Table 1.1.1 Top 10 Countries for Installations and Total Installed Capacity In 2016 [1]

Table 1.1.1 illustrates ten countries that spent the most on PV power. In Asia, China, which is the world leader in PV power, has increased its capacity by 15.2 GW in 2015 and 34.45 GW in 2016 and reached to 78.1 GW total installed PV power capacity end of 2016. In this sector, among the countries that follow China, there are Japan (8,6 GW), Korea (850 MW), Australia (839 MW), Philippines (756 MW), Thailand (729 MW) and Taiwan (368 MW). With the economic breakthroughs it has made in recent years, India has reached 4 GW installation [1].

In the Americas, US invested 14.7 GW in 2016, and the total installed PV capacity of US market has increased to 42 GW. It is expected that Chile (746

MW), Mexico (100 MW) and Brazil will be a more significant player in the coming years [1].

In Europa, the market, which is down every year until 2015, broke this trend with the upward trend in 2015. The biggest reason for the market declines in the previous years was that the UK slowed down its investments. However, with the investment of 2 GW in 2016, UK is the country that accelerates the PV energy investments of Europe. Countries from behind the UK are seen as Germany (1,5 GW), France (0,6 GW) and Italy (373 MW), respectively [1].

In the Middle East region, the government incentives offered by the Energy Ministry in Turkey, helped the markets to achieve investment amount to 583 MW in 2016. For the first time in the history of the country, such a high investment rate has been achieved. Because of the efforts of the Turkey, Israel, UAE, and Jordan, PV market will be able to see more growth rates in the coming years in the Middle East region [1].

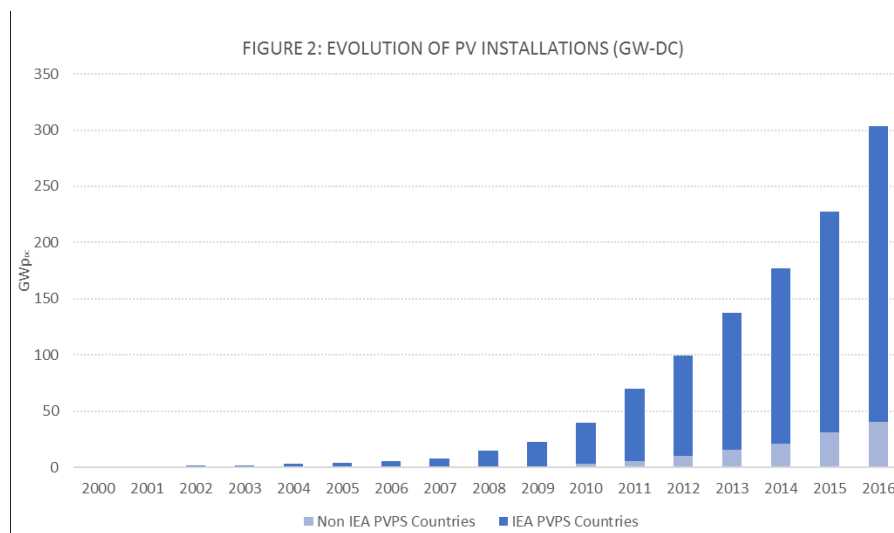

Figure 1.1.2 Evolution of PV Installations (GW-DC) [1]

As seen in Figure 1.1.2, by the end of 2016, globally installed total PV power amounted to 303 GW. GTM Research Team said that by 2022 total installed PV power capacity will exceed 800 GW globally [2][3]. In the long-term scenario,

IEA predicted that worldwide cumulative installed solar photovoltaics (PV) power capacity would reach 4,600 GW in 2050 [3][4].

1.2 PV Power Integration Into The Grid

While the damage that fossil fuels bring to the planet is getting more and more violent every day, many countries and organizations are taking various precautions to mitigate these damages and according to researchers, to address this issue, increasing the use of sustainable and renewable energy resources is the most valid solution so far. As a result of these factors, renewable energy-based distributed generation models that are experiencing a significant increase in the amount of usage due to environmental concerns have forced electric power systems to radical changes in recent years [5]–[8]. As a consequence of technological developments and the economic effects of government policies, the PV power market has emerged as a rising trend among other types of renewable energy, but PV power, though promising in many ways, brings with it many problems, especially about integration into electric power systems.

In traditional power systems, substations are the only source of power, but in modern grids, distributed resources violate this stereotyped approach by resources placed in the distribution system [7]. Especially in low-voltage networks, e.g., microgrids, issues arising from the use of PV may be more dangerous for usage of power on customer-side. Since PV power is not considered in the design stages of electric networks, many problems arise from customers' solar energy investments. For instance, if the customers begin to produce more PV power than their needs, the safety and efficiency of the system may ultimately be threatened by frequent outages, excessive overloading, etc. [7]. Apart from the investment preferences of the customers, problems arising from the nature of PV power have put engineers in a difficult situation, particularly in the integration of the electricity grid. Among such issues, maybe the hardest one is the voltage problems that happen because of interruptions in solar radiance caused by cloud

movements. Since the PV power is directly depended on the solar radiance, such interruptions in the solar radiance can cause large-scale fluctuations in PV power levels, and these fluctuations can result with dangerous voltage dips in customer side voltage levels. These voltage fluctuations can occur even in seconds, so it can be complicated to forecast and prevent these problems. These issues can be more hazardous in low voltage grids.

Figure 1.2.1 shows that the challenges encountered while keeping power system in balance can be spread over a broad scale from milliseconds to seasonal timescales[9].

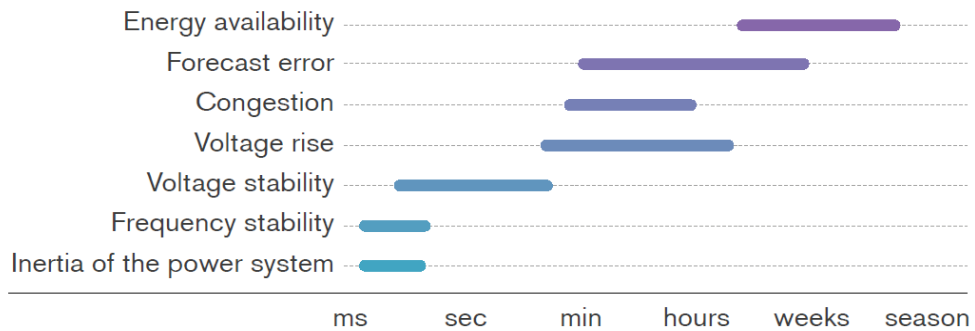

Figure 1.2.1 Grid challenges on different timescales [9]

Some of the fundamental challenges of PV power on electrical networks are listed below [6]:

- it may change feeder voltage level and lead system to imbalance
- impacts the frequent operation of load tap changers (LTC), voltage regulators, capacitor banks and these changes may result with reactive power flow fluctuations
- intermittent nature of solar irradiance can lead to power quality issues, such as voltage fluctuations
- More power generation than needed can cause reverse power flow, and it may result in more electric losses

It should be noted that all these impacts may vary depending on the penetration level of the PV power, the location of generation units or characteristic of the grid system and since PV power outputs change throughout the day, all levels of PV

penetration must be examined separately to cope with all of these challenges [6]. Besides these challenges, the benefits presented by the PV power on electrical networks are listed below [6]:

- it reduces the level of greenhouse gas emissions and helps humanity to fight against climate change
- It improves the power quality and reliability as well as contributes economically to the producer
- by adding consumers into the cycle as an energy producer, load peaks can be smoothed, and energy efficiency can be increased

1.3 Literature Review

Although the history of solar energy dates back to ancient times, we can say that the starting point for us is the second half of the 20th century. Notably, in the 1960s the impact of the oil crisis caused a remarkable increase in solar energy investments. Over the years, cost of solar energy production has been decreasing, and utilization rates have begun to increase, and these developments have attracted the attention of researchers and have led them to focus more on photovoltaic power rather than other energy sources.

One of the first academic studies on the effect of the intermittency of solar radiance on PV power output and voltage profile is [10] Edward C. Kern et al., 1989. The study was made in Gardner, Massachusetts and this paper discusses the slow transients that result in voltage fluctuations that occur in different frequencies. With the help of spatial diversity, they showed that voltage fluctuations could be avoided by reducing the amount of energy produced for the time enough the clouds come out of the region. However, they also presented that numbers of transformer tap changes rose during this time. At the beginning of the 2000s, with the rapid increase in solar energy investments, there was a significant increase in the number of solar energy studies. After 22 years later than Gardner, Massachusetts work, G. K. Ari and Y. Baghzouz

studied on voltage profile effects of 20% PV penetration using 1-minute interval real data for clear and cloudy weather conditions in [11], 2011 and they addressed that voltage fluctuation is not an important issue, but they observed significant increase on transformer tap changes. Emma M. Stewart and co-workers in [12] measured 60 seconds data from 17 sensors placed different areas to obtain real-time cloud coverage data. They suggest to determine effects of PV power on power quality on customer side voltage profile, dramatic drops (from %100 to %20) is not a proper method, and even though industry uses IEEE standards to analyze voltage flickers, for distribution side PV power, market needs real and reliable data about PV characteristics. In his seminal article on voltage stability for residential Customers, Ruifeng Yan et al. [13] says that among studies made until now, very few of them have worked on voltage stability analysis for small networks, so he draws our attention to voltage analysis of low voltage grids. In his results, he claims the cloud effect becomes an important challenge for the voltage profile when the system uses 40% of the required power from the PV power. Additionally, one of his valuable findings is that voltage issues can be reduced by using static loads instead of dynamic loads. In [14], Ashish Agrawal et al., compared two types of PV generation control methods, Volt-VAR control, and constant power factor control. These methods are tested for voltage profiles in the distribution system and transmission system and depending on the outcomes obtained as a result of the studies, the control methods to be integrated may vary according to preferences in distribution and transmission systems. Danling Cheng [15] et al. presented a real case approach. They worked on the effects of gradual PV penetration in two distribution networks with high penetration rates in California and examined unrealistic PV penetration rates to determine the limitations of PV integration in future cases. As a conclusion, they proposed PV PF control methods for the different circuit in different scenarios. Rahimi and co-workers developed Cloud Motion Simulator (CMS) that is a new method to measure cloud effects on voltage levels in [16]. Also, with the help of the CMS, impacts of cloud speed, their width and time interval between them on voltage fluctuations are studied in

two cases, and they proposed significantly detailed numerical data about impacts of clouds on voltage profile. Ruifeng Yan and Tapan Kumar Saha in [17], focused that line characteristics could be affected by changes in PV power output and can end up with different voltage drops in each phase such as unbalance voltage levels in the remote bus, reaching excessive low voltage levels in one phase, so they analyzed voltage changes that happen because of PV power output differences and presented new network reconfiguration method as a solution to voltage issues for network planning in unbalanced networks. In [18] Mustafa A. Zehir et al., proposed a detailed analyze of bus voltages and network losses for critical cases in microgrids by analyzing daily demand profiles, the seasonal output of distributed generations. In [19], effects of rooftop solar PV power on voltages levels at service transformer in small residential area is investigated by Abhineet Parchure et al. The goal of this study is to give suggestions, by trying varied secondary side scenarios, about impacts of intermittent PV generation profile on voltage levels of service transformer for secondary system settings. Achim Woyte et al. implemented localized spectral analysis to solar radiance in [20] to decide the characteristics of power fluctuations and they made power flow analyzes in order to examine the effects of varied solar radiance on the voltage levels. In a different work, to find out appropriate configurations for energy storage system in Northern European countries, Schnabel investigated PV power fluctuations [21]. Also, the goal of the study was to provide real-life adaptive findings of systems with PV and energy storages. In his thesis study [22], Joel A. Nelson focused on impacts of cloud-induced photovoltaic transients on protection and operation of the electrical grid. He also examined the effects of cloud shadows on the harmonics produced by the inverters in the PV generation systems and proposed a cost-saving, reliable way to operate PV systems. Yun Tiam Tan [23] studied on the correlation between steady-state and dynamic characteristics of electrical systems and photovoltaic power and tried to reduce harmful impacts of PV generation on power system such as instantaneous changes in solar radiance because of cloud movements. To keep voltage level in balance and to protect the

system from voltage fluctuations he suggested three control methods, power factor control, Static VAR Compensator (SVC), PV inverter voltage control. As a conclusion, he proposed PV inverter voltage control as the most successful method to minimize voltage fluctuation issues. V. Cirjaleanu [24] investigated the maximum PV power level that could be used in the grid without a voltage stability problem despite the negative effects caused by the clouds and also worked on differences in the system operation when the system is under cloud effect, due to the characteristics of dynamic and static loads. End of his work, he stated that in the dynamic load modeled systems, when PV power integration levels reach to %50, could cause a problem in voltage stability. However, the same problem was not encountered in static modeling systems. In [25], Begovic et al. studied the effects of PV power on the system planning and operation for the industrial area, and they presented precautions to address these issues such as reducing costs, environmental aspects, etc. Ruifeng Yang and co-workers worked on real-life urban networks and used real historical data in [26]. They compared effects of the cloud-induced PV power fluctuations on the voltage profile of the network for the two cases where the PV power resources are connected to the low and high voltage sides of the substation. In [27], Xiaodong Liang proposed a detailed literature study on power quality issues due to the integration of renewable energy resources into the power systems. In her paper, she especially focused on control techniques such as virtual synchronous generator and virtual impedance control methods to enhance power quality under bad circumstances, and she recommended some research areas that will become valuable in the future. Another real case study came from Adam Kankiewicz et al [28]. They investigated the effects of cloud movements on 25 MW PV plant in Florida for a day. They presented that by increasing the amount of PV power generation and spreading them over a large area, production can suffer less from clouds and they also added that in order to get more accurate results, we need to investigate the impacts of the sizes, speeds, and shapes of the clouds.

1.4 Thesis Scope

The world is facing more and more energy needs, and the most significant sources of energy currently used are fossil fuels. The damage caused by fossil fuels induce many problems, especially air, water, and environmental pollution. In addition to the damage they give to the environment, fossil energy sources are rapidly depleting. If we continue at this rate of energy consumption, fossil fuels are expected to be consumed in as short as 50 years. For this reason, we must make all energy processes more sustainable in order to meet the needs of future generations and the most valid method for this is to use renewable energy resources [29]. The main types of renewable energy resources are solar energy, wind power, hydroelectric energy, biomass, hydrogen, and fuel cells, geothermal power. These types of renewable energy resources are very reliable systems because they are both natural and cheap. However, solar energy is one of the renewable energy resources that attract the most attention among renewable energy types. However, besides its positive aspects, solar energy, like other types of renewable energy resources, comes with many important issues. Although the types of these problems vary widely, this study focuses on cloud effects on both PV power output and voltage levels, which is one of the most critical problems that solar energy production experiences.

Studies have shown that, if measures are not taken, both large and small investments are vulnerable to sudden changes in the solar radiance. Although the number of works done increases day by day, the system planners still need to know the characteristics of the sudden changes in solar irradiance. Because understanding the causes of these PV power fluctuations will help us to establish reliable standards in the networks such as microgrids where solar energy is the primary producer of energy [22]. Although many studies specifically examine the effects of clouds on high voltage networks, in the literature, there are not enough studies about the impacts of clouds on voltage fluctuations in low voltage networks such as microgrids.

This study investigates the impacts of cloud-induced PV impact on the voltage profiles in unique real-life microgrid design. Three different case studies were created and performed to analyze the results of these effects. This microgrid design will be implemented in the Malta College of Arts Science and Technology (MCAST) campus. The solar irradiance and clouds data used for the analysis in this work are specific to the Mediterranean region. The results in this work are based on the project called 3DMicroGrid that is ERANETMED funded project.

1.5 Overview of the Thesis

Chapter I of the thesis begins by giving information about the past, present, and future of solar energy. After the detailed literature review, the contribution of the thesis to the scientific society is mentioned.

Chapter II starts with the general introduction of the microgrid concept. After the brief introduction, detailed review -types, operation, and control- of the microgrid concept is given. Finally, this section ends with the advantages and disadvantages of microgrid systems.

All technical details of the 3DMicroGrid design are given in Chapter III. Later than the technical architecture, the information of MATLAB/Simulink simulation model which is used in this thesis work is mentioned.

Chapter IV contains all the scenarios and results that are constructed and implemented in the thesis study. The technical comments about the results obtained from the simulation are also presented to the reader in this section.

Chapter V consists of the conclusion section. The outcomes of the study and the discussions about future studies are addressed here.

Chapter 2

Microgrid

The growing need for energy day-to-day is considered the primary source of many problems, from the economic growth of countries to technological developments. Besides these problems, traditional methods of generating electricity, are based on fossil fuels, which account for %30 of the pollution in the atmosphere. This situation leaves us with serious environmental problems. So because of these issues, governments around the world are making a variety of legislative acts to direct investors' attention to renewable energy that is the most important method that can solve environmental problems. As a result of these developments, to modernize structures of power systems, the world has begun to shift to decentralized generation methods such as solar and wind energy from centralized generation method that led to the use of fossil fuels [30]. Notably, under the leadership of distributed energy resources, power systems have started to adapt to global expectations by modernizing and changing rapidly. Naturally, these changes come with many challenges at every stage of the power system structure, but advantages such as easy installation, increased reliability and economic savings offered by distributed energy resources (DER) makes DER technology more attractive in society. As a result of the efforts to successfully integrate distributed energy resources and its auxiliary technologies into the electricity network, the power globe has developed a new concept of microgrid which is a local energy system that can work together with the macro electrical network or on its own [31]. Microgrids are the most crucial piece in the modernization of traditional electricity networks, and the next subtitle gives detailed information about the microgrid concept.

2.1 New Concept: Microgrid

Microgrids are small-scale energy networks with specific boundaries that can be operated independently or network-dependent, with their energy resources, productions and loads. It offers many significant advantages such as providing energy supply in independent areas of the network with on-site microgrid production, reducing transmission losses between regions, increasing service quality by detecting failures instantly, efficiently using resources by supporting demand management, more local resources, more durable and dynamic network. Although the primary goal is to provide clean, cost-effective and safe energy to urban and rural societies, microgrids can offer essential solutions to the commercial and industrial areas regarding energy demand.

The main areas of utilization for microgrids are as follows [32]:

- Urban and Rural Areas
- Industrial Areas
- Agricultural Areas and Forests
- Hospitals and Campuses
- Military Barracks

Microgrids can be thought of as miniaturized traditional power grids. Therefore, every element and function in the main power grid must also be present in the microgrids such as power generation, distribution, and control, etc. Unlike the macro power networks, in microgrids, efficiency is higher, and losses are lower because the energy production and use take place nearby. Also, distributed energy resources such as photovoltaic power, wind power can be integrated more easily into microgrids compared to larger grids [33]. As in every power network, one of the main tasks of the microgrids is to keep the system in the balance against any possible faults. So as a unique characteristic of microgrids, unlike traditional grids, they can isolate itself from the main electrical grid during faults and ensure that the operation of its network continues smoothly. Also, microgrids can isolate themselves from the main power grid even when

the quality of electricity from the main power grid falls below certain standards [34].

Some of the qualifications of microgrids are as follows [34]:

- Offers many options for electricity generation.
- Reduces energy costs by allowing customers to generate and manage their electricity.
- In addition to providing voltage and frequency protection in islanding mode, it also enables seamless connection by performing the necessary synchronizations during reconnection to the main power grid.
- Distributed energy resources can meet the energy demands of customers during islanding mode.
- It can serve a variety of areas such as residential, commercial, industrial.
- Provides high-level power quality.
- It may continue to provide energy to users during emergencies or major blackouts.
- It makes the network more resistant to physical or cyber attacks.
- Detects the problem in the system and protects the energy supply of the system without causing power interruption.
- By providing real-time information to the customers, it increases their control over the grid.

2.1.1 Types of Microgrids

Microgrids may differ according to the characteristics of the region they serve. Generally, microgrid types can be grouped into four categories [35] [36].

2.1.1.1 Campus Microgrids

These types of microgrids serve in a tight geographical area. Loads in these microgrids do not have very high energy consumption, so it can easily be managed. Often it works connected to the main electrical grid, but it can also switch to the island mode when there is a problem in the macro electrical grid.

University campuses are one of the most suited examples for such microgrids [35] [36].

2.1.1.2 Remote “Off-grid” Microgrids

These microgrids have no connection with the macro electrical network because of geographical disadvantages of their own. Because of this reason they always have to operate in islanding mode. The best examples of such microgrids are islands or remote settlements because they are not in a region close to any distribution and transmission network [35] [36].

2.1.1.3 Commercial and Industrial (C&I) Microgrids

Such microgrids serve commercial and industrial areas, so the power quality and security they provide are of great importance. Because in these regions, an energy supply related problem that may arise in manufacturing processes may cause substantial economic losses [35] [36].

2.1.1.4 Military Base Microgrids

These types of microgrids serve military barracks, prisons, etc. In these microgrids, cyber and physical security must be at the highest level because all buildings indirectly contain national security concerns [35] [36].

2.1.2 Architecture of Microgrid

As seen in Figure 2.1.2.1, main components of microgrids are distributed generation resources, energy storage systems, control and communication systems, loads and PCC (point of common coupling) which is the connection point between the main power grid and microgrid.

The individual system components for microgrids are as follows [32]:

- Renewable Energy Systems
- Energy Storage and Management Systems
- Generators
- Measurement and Control Systems

- Power Converter Systems
- Energy Management Systems
- Communication and Information Security Systems
- Electrical Grid Connection Systems
- Loads

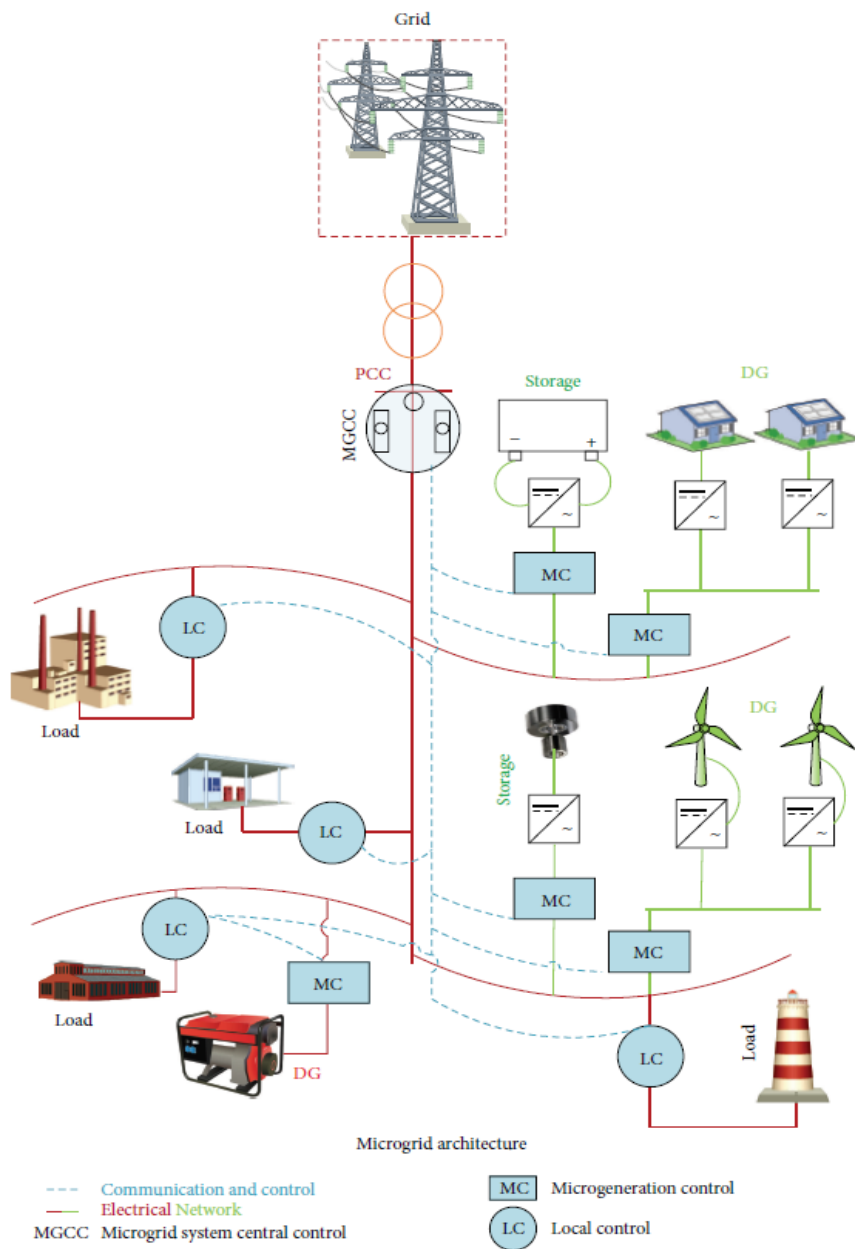

Figure 2.1.2.1 Simple microgrid architecture [37]

2.1.2.1 Distributed Generation (DG)

In the microgrids, energy is produced by distributed generators (DG) in the location where the power is consumed. There are two types of energy generation technology, renewable, and non-renewable energy resources. Photovoltaic power (PV), wind, hydropower, etc. are as renewable energy resources while Combined Heat and Power (CHP), reciprocating engines, gas turbines are among non-renewable energy resources. Power electronics technologies are of great importance regarding distributed generators (DG). All of the power converters that used during the conversion of the energy from one form to another before the usage such as DC-DC, DC-AC are belong the power electronics discipline [38].

2.1.2.2 Energy Storage Devices

Energy storage technologies are one of the most critical components that keep microgrid operation running smoothly. They may increase the quality, durability, efficiency, and balance of the energy provided to the customers [38]. The functions of storage devices in microgrids can be summarized as follows [30] [39]:

- Soften the adverse effects of the power fluctuations that occur during distributed generators' energy generation.
- They meet initial energy need while microgrid switching to the islanded mode from grid connected.
- At times when the energy needs peaks, they can serve as an auxiliary resource for distributed generators (DG).

Since the storage devices to be used differ according to the characteristic structure of the microgrid, the needs of the grid must be considered before making the selection [38].

2.1.2.3 Loads

Microgrids can be established in very different regions regarding customers, structure, and expectation. For instance, if we think about the customers, the

microgrid can serve in two regions with very different expectations, such as industrial and residential. Therefore, anticipations should be analyzed in detail before starting to build microgrids [39].

2.1.2.4 Control and Communication Systems

Control in microgrids can be grouped under two main headings: centralized and decentralized. In the central control, information transfer takes place between the units and the decision is made by a single authority. So, in some situations, an important issue may arise in practice, as the power systems are interconnected and spread over a wide area and contain numerous components. In other respects, in decentralized control, each unit is controlled by its control mechanism without receiving information from other units. In practice, the operations of some units in the system are significantly dependent on each other's situation. Therefore, decentralized control can disrupt such units. Because of this reason, control operations of microgrids are mostly formed in a combination of two styles rather than relying on only one control style [35].

Communication systems are considered to be the most critical unit in microgrids when it comes to power protection and control mechanisms. The main communication technologies used in real-life microgrid designs are GSM, LAN/WAN/Internet (TCP/IP), optic fiber, radio communication, WiFi 802.11b, WiMAX 802.16, ZigBee/IEEE 802.15.4, power-line carrier, leased telephone line [37].

2.1.2.5 Point of common coupling (PCC)

It is the point where the microgrid and the main power grid are connected. The PCC connects the microgrid to the main electrical grid as long as there is no problem and it also keeps the voltage at the same level as the main grid [35] [40]. When the main grid experience a problem, it is the PCC's most important task to disconnect the microgrid from the main network and to switch it to islanded mode.

Table 2.1 [37] provides detailed information on some of the existing microgrid designs in Europe to analyze the structure of the different microgrid architectures.

Location	Power Supply	DG Source	Energy Storage	Microgrid Controller	Communication
Bronsberg, Netherlands	AC	PV	Battery	Central	GSM Communication
Am Steinweg, Germany	AC	PV, CHP	Battery	Agent-Based	TCP/IP
CESI RICERCA DER, Italy	DC	PV, Wind, Diesel, CHP	Battery	Central	Combination of LAN, ethernet, wireless and power line
Bornholm, Denmark	AC	Diesel, Wind	None	Autonomous	Optical fiber network
Kythnos, Greece	AC	PV, Diesel	Battery	Central	Powerline
CAT, Wales, UK	AC	Hydro, Wind, PV	Battery	Central	Not discussed

Table 2.1.2.1 Microgrid examples in Europe [37]

2.1.3 Operation and Control of Microgrid

Microgrids may continue to operate either with the main power grid or in islanded mode. When the microgrid is connected to the main grid, if distributed generators produce more energy than microgrid need, it gives extra power to the grid. Otherwise, it can use power from it. When a problem occurs in the main

grid, microgrid should switch to the islanded mode as soon as possible. It is a serious and challenging task to adjust the voltage and frequency values during this transition. Because the main grid is responsible for setting these values while the microgrid is operating in grid-connected mode. However, when the microgrid switches to islanded mode, its control mechanism should manipulate these values. If the microgrid is drawing power from the main grid before it goes to the islanded mode, the generators and energy storage systems have prominent tasks during the transition to islanded mode. The control units should quickly energize the generators and energy storage systems since the amount of energy generated by the distributed generators will be insufficient against the loads. Also, energy storage systems and generators must be selected at such a capacity to be able to respond to these quick requests as required [31].

The general tasks to be performed by the control mechanism can be summarized as follows so that the microgrid can continue to operate smoothly [41]:

- Active and reactive power exchanges must be managed smoothly by the requirements of the microgrid.
- Transitions between grid-connected mode and islanded mode should be performed without any problems.
- Should not allow any power interruption and quality degradation during the flow of energy to sensitive loads, such as industrial and commercial.
- Should provide an optimized balance between DG, energy storages and generators.

Control methods can be grouped under two main headings, centralized and decentralized controls.

2.1.3.1 Centralized Control

In the centralized control method, data is taken from all units in the microgrid and combined into a single center, where decisions of all units are taken and sent back to the units. This method is ideal for small microgrids. Low reliability, communication issues, and shutting down the whole system in a problematic situation can be said to be the negative aspects of this control method. Also,

economically speaking, centralized control is a more profitable approach than decentralized control [38].

Centralized Control usually consists of three layers;

- 1) *Local controllers*
- 2) *Microgrid central controllers (MGCC)*
- 3) *Distribution management system (DMS)*

Local measurements required to manage voltage and frequency values are made at local controllers, without any data communication. MGCC is responsible for the energy management of the microgrid. It manages active power outputs of DG and energy demands of loads. In order to DMS to work, all microgrids must have MGCC layer [38].

2.1.3.2 Decentralized Control

The decentralized control method provides a more independent control environment for each unit of the microgrid. This type of control method should be preferred if the characteristics of the areas served by the microgrid differ from each other. In this method, the data exchanges are made on a communication bus to which the local controllers are connected. The multi-agent system (MAS) is the most appropriate example for a decentralized control method to use in complicated systems.

When it comes to comparing two control methods, decentralized control requires less computing power than centralized control. Also, when a new unit is included in the microgrid, with the plug-and-play approach, the new unit can be easily adapted to the control system without changing the entire control system [38].

2.1.4 Benefits and Challenges of Microgrid

The microgrid concept does not only change the structure of traditional grids from day to day, but also it rapidly transforms our knowledge of power systems. However, as the applications of microgrid increase, it also brings with it certain

benefits and challenges and a general list of these benefits and challenges can be given as follows [30] [42]:

Benefits of microgrid

- When a problem occurs in the main power grid, the microgrid may isolate itself and continue to operate smoothly.
- During peak times, the microgrid may prevent the failure in the main grid by supporting it to reduce the energy needs of the loads.
- Microgrids have a positive impact on the environment by reducing the greenhouse gas emission.
- In microgrids, electricity is generated where customers consume it, so there are no energy inefficiency problems caused by long transmission lines.
- The electricity costs are lower in microgrids. Because customers can generate their electricity by distributed energy resources (DER).
- It can be established in geographically challenging places where the grid may not be built.

Challenges of microgrid

- In microgrids, keeping voltage and frequency values by the specified standards may become a more demanding task in some special cases.
- Making the necessary synchronizations in case of switching to the islanded mode or reconnecting to the grid is a critical and challenging task.
- If the physical and cyber security of the microgrid is not robust enough, private data, etc. may be compromised.
- Operate a large number of DGs together can create confusion in the operation of the microgrid system.
- If the characteristics of the area to which the microgrid serve cannot be analyzed correctly, the selected equipment, such as energy storage

devices, etc. will be inadequate and may not prevent severe disturbances in the grid.

- Since distributed energy resources' (DER) energy productions are unpredictable, sudden and significant interruptions in energy generation may occur.

In order to analyze all these advantages and disadvantages correctly, it is necessary to increase the real-life microgrid designs. In addition, to support the theoretical knowledge with practical applications, this will be a promising start to overcome our problems such as energy shortages and climate change that have reached critical points for our planet.

Chapter 3

3DMicroGrid

3DMicroGrid is a smart microgrid design to integrate and optimize several small to medium sized energy sources and loads. The main purpose is to benefit from local renewable energy resources and adapt them to sustainable solutions that can meet electricity demand and supply. In the first stage, the demo of the smart microgrid design will be constructed to achieve the following objectives:

- i. The highest level of use of renewable energy sources.
- ii. Decrease carbon footprint rates with the help of renewable energy resources.
- iii. Increase the power quality while providing economic feasibility.
- iv. Produce similar designs for institutions, commercial and rural areas

3DMicroGrid organizes a detailed campus plan based on different energy scenarios, containing: energy consumption; load classification; energy generation efficiency; consumption models, such as scenarios specified according to human's energy consume behaviors; power quality according to main grid's power, switching among differently distributed energy generators.

3DMicroGrid will be established on a smart infrastructure; besides the traditional framework, it will use next-generation systems, such as software systems, sensors, smart meters, modern hardware. Various energy saving scenarios will be investigated, with the help of different forecasting techniques, such as load forecasting, grid's blackout characteristics, choosing suitable DGs concerning conditions, weather forecasting for energy generation. Given the economic and technological benefits it provides, we can clearly say that the 3DMicroGrid smart microgrid design will be very beneficial for both utilities and customers as well as for our planet [43].

3.1 Objectives of 3DMicroGrid

The main goal of the project is to establish 3DMicroGrid design in Malta College of Arts Science and Technology Campus. In addition, with the help of innovative methods that can be obtained using real field data, the accuracy and reliability of the microgrid design to be integrated will be enhanced.

The primary academic and technical objectives are as follows:

- An open source smart microgrid framework is planned to be developed at the end of the project.
- Create scalable modularized designs of smart microgrid functions.
- To provide voltage, frequency and load control through decentralized control disciplines.
- Enhancing more durable autonomous agents for the smart microgrid approach.

3.2 Benefits and Novelty of 3DMicroGrid

The benefits of the 3DMicroGrid Project are; reduced greenhouse gas emissions through the use of renewable energy resources, increased power quality, enhanced energy efficiency due to reduced transmission losses, simplified and localized grid control, increased grid reliability and durability with the help of different energy sources and testing the validity of the theoretical knowledge about microgrids in real life [43].

Besides the benefits to be provided, the novelty to be presented through the project is; presenting the most advanced and modern microgrid paradigm in the literature through next-generation technologies removing uncertainties, such as load demand, energy generation of DERs, market prices, etc. [43].

3.3 3DMicroGrid Architecture

The first version of the 3DMicroGrid high-level system architecture is shown in Figure 3.3.1.

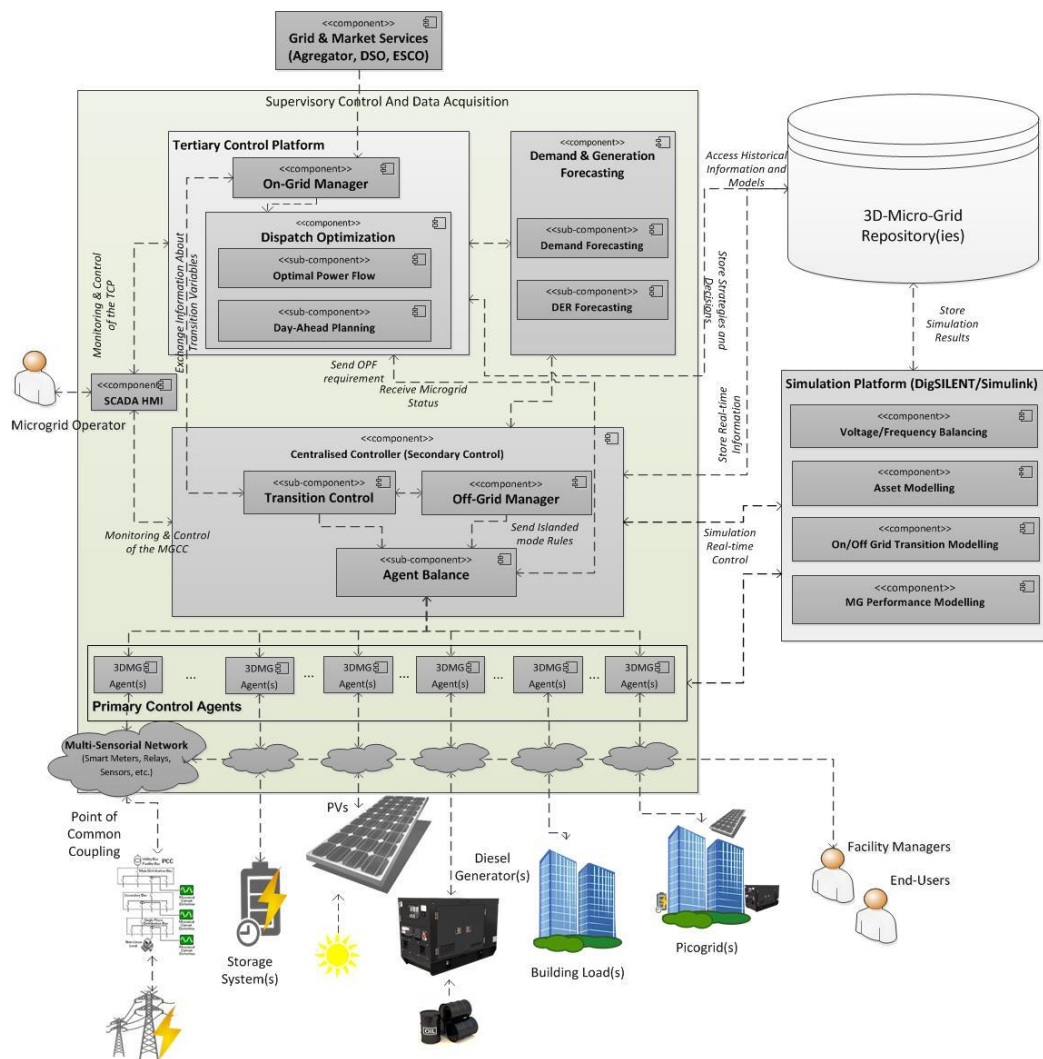

Figure 3.3.1 3DMicroGrid system architecture

As given in Figure 3.1, according to the 3DMicroGrid framework, the monitoring and control operations are based on the Supervisory Control and Data Acquisition (SCADA) system, which is harbored many units that will enable the project to reach the objectives. The main idea of this architectural

plan is based on the microgrid control approach that becomes stereotyped for microgrids, consisting of primary, secondary and tertiary control levels that combined with the agent-based paradigm. From top to bottom, the descriptions and explanations of each element in architecture will be given in the next parts. The SCADA platform has been created with the help of an open source platform to ensure that optimal configurations are achieved without waste of time and that the architectural design of the microgrid is easily operational.

3.3.1 Grid & Market Services

The 3DMicroGrid system continually exchanges information with the main grid and market (e.g., voltage or frequency levels, prices) to ensure efficient and sustainable energy transfer between the distribution system and the Microgrid. Grid Services are obtained directly from the grid via the On-Grid Manager. However, power flow information is obtained from the PCC thanks to the multi-sensorial infrastructure. The Grid Services are responsible for receiving information, which is not found in the PCC and necessary for the Microgrid to operate smoothly in the grid-connected mode, from the main network stakeholders and presenting them to the control system.

3.3.2 Tertiary Control Platform

This part is responsible for the tertiary level of control information. This unit is often responsible for the operational planning of the Microgrid. For instance, it uses the information from the lower control levels to determine the energy strategies of the system and makes fiscal adjustments with the help of the data received from the grid. This control unit has two components.

3.3.2.1 On-Grid Manager

This software unit works as the communication unit between the Tertiary Control Platform (TCP) and Grid & Market Services. When a signal or service arrives from the grid, it is transmitted directly to the Dispatch Optimization unit or stored for access by other circuit units. Also, before the Microgrid switch to

islanded mode, data communication is initiated with the Transition Control unit to determine the required variables.

3.3.2.2 Dispatch Optimization

In this unit, tools that will evaluate real-time conditions and results of the Simulation Platform will determine the short-term and medium-term operations of the 3DMicroGrid. It has two sub-units. First one is Optimal Power Flow, which is the unit that calculates corrective operation of the system (active & reactive power consumption, voltage rise or drop, etc.) based on the DSO / ESCO requirements. The second one is Day-Ahead Planning, which is the sub-unit that makes future scheduling, such as forecasting, etc.

3.3.3 Centralized Controller (Secondary Control Platform)

The Secondary Control will be in the Microgrid Centralized Controller (MGCC), which is responsible for the communication infrastructure needed to perform operations, such as cost, measurement needs. 3DMicroGrid provides a hybrid paradigm that includes both centralized and decentralized methods. The optimal balance for control operations can easily be achieved using MGCC responsible for the second control and an agent-based infrastructure for the primary control. Also, MGCC is responsible for applying the strategies defined by TCP. The centralized control consists of three units.

3.3.3.1 Off-Grid Manager (Islanding Mode)

This unit is responsible for determining the rules needed to manage operations during the islanded mode. By linking this unit directly to the Agent Balance component, it gets more control over the agents and ensures that each agent contributes more to the robustness of the grid's operation.

3.3.3.2 Transition Control

This module's responsibility is to communicate with On-Grid Manager and Off-Grid Manager to evaluate conditions while switching between grid-connected

mode and islanded mode. After reviewing the conditions, the Transition Control informs the other units about the suitability of the transition. After this step, it determines the variables needed for this transition. With this information, the MGCC can transmit the proper set-points to the units such as the generator, energy storage, etc. to keep the voltage and frequency values stable during the transition.

3.3.3.3 Agent Balance

According to the energy strategy provided by Tertiary Control Platform (TCP), the Agent Balance unit coordinates and manages the operation of all agents connected to the MGCC at the primary control level. Taking into account the stability and reliability of the Microgrid and anticipating the problems that may be encountered in Microgrid operation, the Agent Balance unit manipulates the rules applied by the agents according to the conditions.

3.3.4 Agents – Local Controllers (Primary Control Agents)

Each asset type, such as load, PV, energy storages, diesel generator, etc., is controlled by its Agent that is in charge for balancing conditions of them about voltage, frequency levels, etc. The Master-Slave approach is applied to make the agent-based control system more modular and scalable at the primary control level. With this approach, the primary control level can easily operate as a fully centralized or fully decentralized.

3.3.5 Demand & Generation Forecasting (DGF)

This module is responsible for forecasting the demand requirements of the microgrid and determining the amount of energy required. In addition to estimating the load of the grid, it has to make necessary forecasts for the future performance of renewable energy resources and notify to the system.

Also, this unit presents a series of scenarios with the possibility of emerging to TCP and MGCC using stochastic forecasting techniques of generation and demand.

3.3.6 Multi-Sensorial Network

All the sensors needed for the microgrid will be analyzed and maintained in this section for both monitoring and control. Smart Meters will be connected to existing infrastructure in communication without interfering monitoring and control systems.

3.3.7 SCADA Human-Machine Interaction (HMI)

This unit is an interface that will help the Microgrid Operator to access the Microgrid system. Also, this interface will have access to all the information gathered in the general SCADA system and will give control features on the Microgrid system. User-friendly, improved visualization (Visual Analytics) will be provided to understand better and control Microgrid units and simplify and enhance the information obtained from Microgrid.

3.3.8 3DMicroGrid Repository

All data provided by the Microgrid system is stored in this common repository that is accessible via the web-based API or SCADA.

3.3.9 Simulation Platform (MATLAB/Simulink)

The simulation stage of the Microgrid design has an extremely critical precaution. Before implementation of the design in the real field, all aspects that need to be developed need to be researched and their results evaluated in the simulation platform. For this purpose, a simulation platform will analyze real and historical data using the correct and dynamic models to find optimal work plan for the various detailed scenarios, and it will show potential developments and drawbacks of the system for the real field applications. All the simulations required for the 3DMicroGrid design were executed in MATLAB/Simulink simulation environment, and Figure 3.3.9.1 shows MATLAB/Simulink model of 3DMicroGrid.

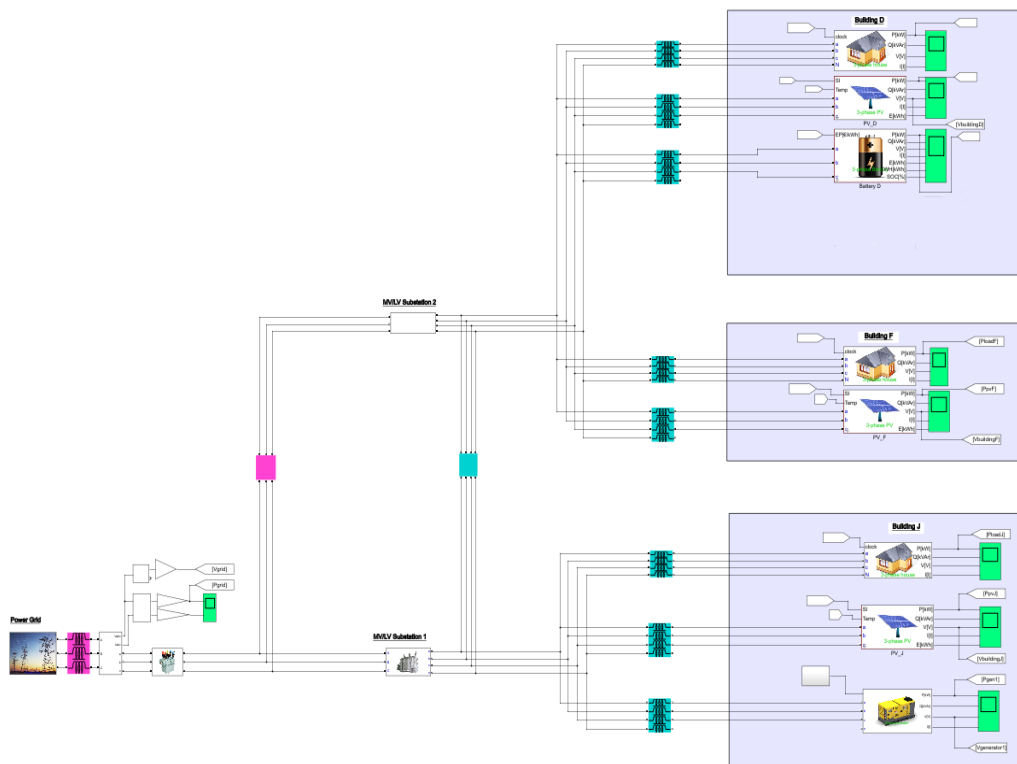

Figure 3.3.9.1 3DMicroGrid MATLAB/Simulink model

Essential details of the main parts of the simulation design are shared below.



Figure 3.3.9.2 3DMicroGrid MATLAB/Simulink building model - controllable and uncontrollable loads

Figure 3.3.9.2 shows the model of a building load as a block in MATLAB/Simulink. It was created as a three-phase load model (4-wire,

unbalanced) according to seasonal load profiles. Typical load profiles have been used for load data.

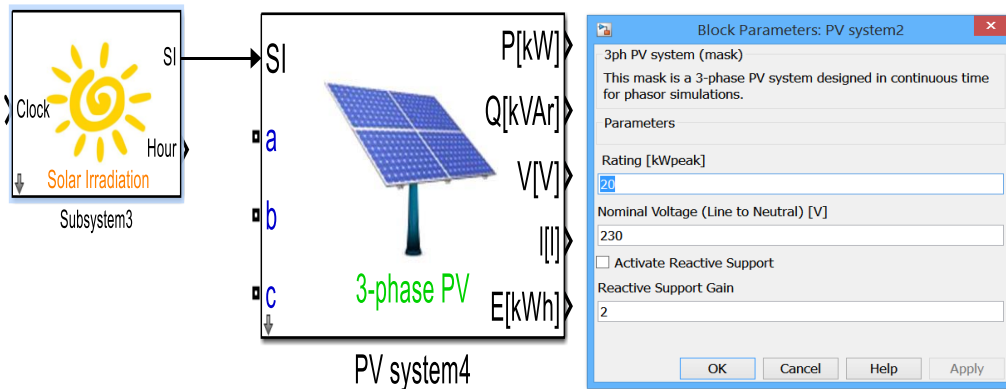

Figure 3.3.9.3 3DMicroGrid MATLAB/Simulink PV system model

Figure 3.3.9.3 shows the model of a PV system as a block in MATLAB/Simulink. 3-wire interconnection and 24 hours solar irradiance profile were used for input to the PV system block. Also, the block may be present in reactive power support when voltage sag occurs in the system.

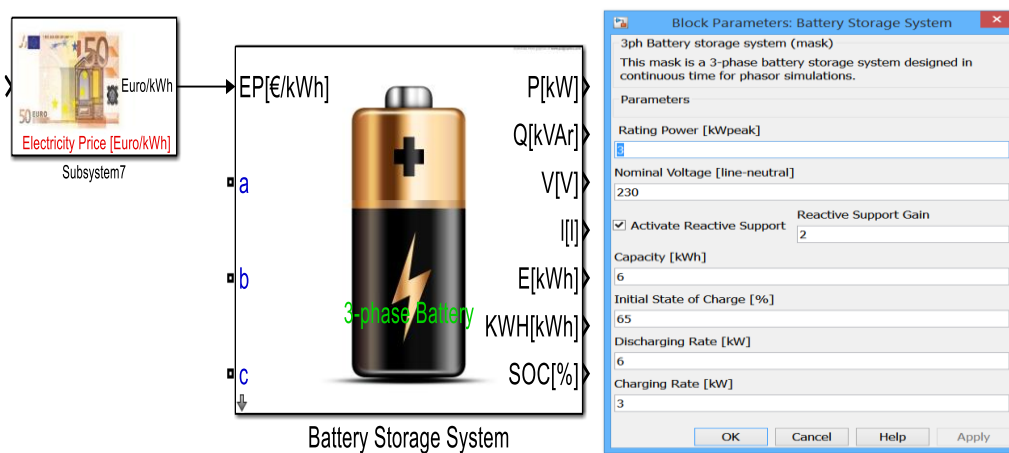

Figure 3.3.9.4 3DMicroGrid MATLAB/Simulink battery storage system (BSS) model

Figure 3.3.9.4 shows the model of a battery storage system (BSS) as a block in MATLAB/Simulink. As inputs, BSS has 3-wire interconnection and variable pricing environment. Also, it allows the user to control rating power, the

capacity of the battery, charging and discharging rates, the initial state of charge. From the output of the battery block, active power, reactive power, voltage, current and state of charge graphs can be obtained for a 24-hour period.

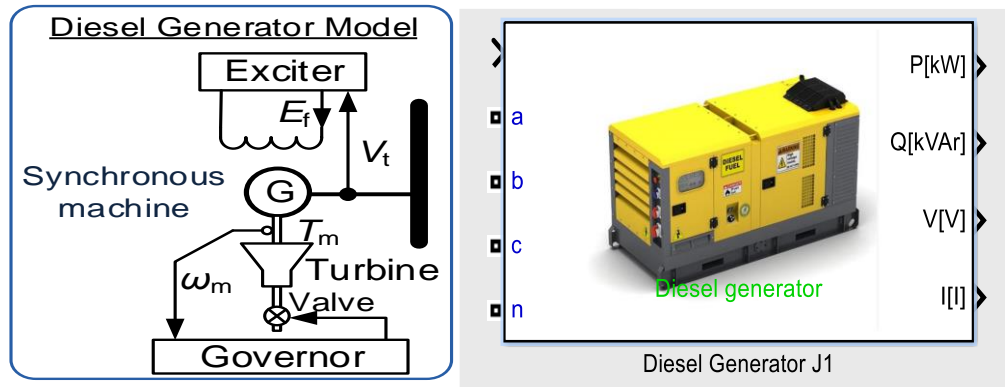

Figure 3.3.9.5 3DMicroGrid MATLAB/Simulink diesel generator model

Figure 3.3.9.5 shows the model of a diesel generator model in MATLAB/Simulink. To model the generator sixth-order state space model (500 kVA) was used. For the exciter, the IEEE type AC5A model was used. Also, governor of the generator design is PI controlled based model. The diesel generator will be the master in case of islanding mode.

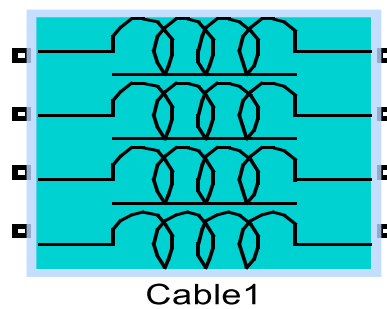

Figure 3.3.9.6 3DMicroGrid MATLAB/Simulink underground cable model

Figure 3.3.9.6 shows the model of an underground cable in MATLAB/Simulink. As a cable conductor, Aluminium or Copper model was used. Also, the cable model constitutes 4-wires.

As we can see from Figure 3.3.9.7, The 3DMicroGrid plan forms part of the MCAST campus and consists of 3 buildings (Block D, Block F, Block J) and two substations (SS1 and SS2). Substations are in a closed room, and they have two parts: high voltage (HV) (11 kV) switchgear and low voltage (LV) (400 V) switchgear. They meet the energy needs of 3 different buildings. Each building has 21 kW PV system. Also, they have controllable and uncontrollable loads. In addition, Block D and Block J have different assets besides the rooftop PV power system. Block D has the 15 kW battery storage system, and Block J has a powerful diesel generator to keep the system stable while operating on islanded mode. Table 3.3.9.1 gives details of assets and load types of all buildings. Lastly, all buildings and substations are connected by underground cables.

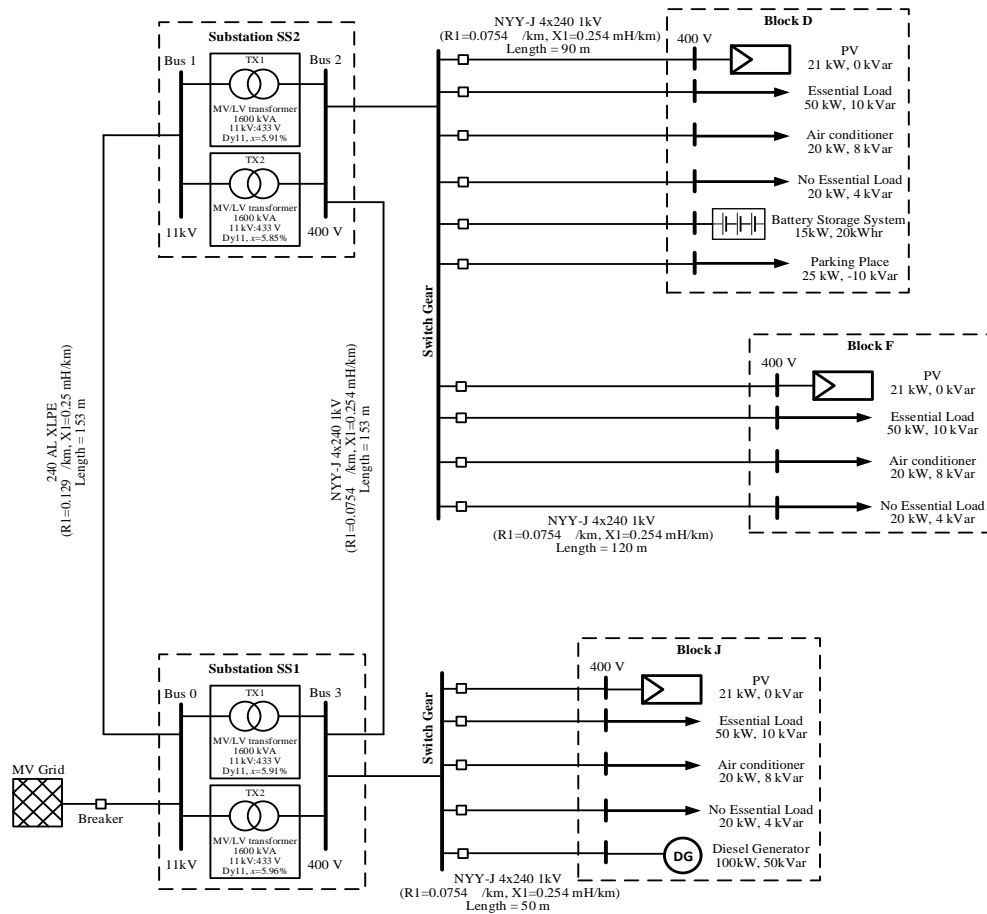

Figure 3.3.9.7 The electrical network plan of the 3DMicroGrid

	Building D	Building F	Building J
PV Power	21kW	21kW	21kW
Battery	15kW		
Diesel Generator			500kVA
Essential Load	50kW 10kVAR	50kW 10kVAR	50kW 10kVAR
Air Conditioner	20kW 8kVAR	20kW 8kVAR	20kW 8kVAR
Non-Essential Load	20kW 4kVAR	20kW 4kVAR	20kW 4kVAR
Parking Place	25kW -10kVAR		

Table 3.3.9.1 Assets and loads of all buildings in 3DMicroGrid

Chapter 4

Simulation Results

The simulation section of 3DMicroGrid has a vital role in integrating the details and objectives of the project described in chapter 3 into the real field. Simulations of all the scenarios required for the design of the 3DMicroGrid project were performed using the MATLAB/Simulink platform.

4.1 Operation Scenario of 3DMicroGrid

Figure 3.3.9.1 considers the current architecture of the MCAST campus with the Buildings D, F, and J. This is a phasor simulation model and in this simulation model, one-day simulation with a resolution of one minute in the load and solar profiles is run.

In the simulation scenario, the micro-grid starts in interconnected mode at the midnight, then at 02:00 there is a few seconds voltage sag event (where the PV, BSS, and the generator provide reactive support to the grid), then at 03:00 the active power of the diesel generator is change by 50kW according to the set-point. From 08:00 to 20:00 the micro-grid operates in an islanding mode where the diesel generator is the master.

4.2 Cloud Induced PV Impact on Voltage Profiles

As mentioned in Chapter 1, the integration of renewable energy resources in the power grid can face large-scale problems. However, perhaps the most dangerous of these problems are problems caused by weather conditions especially cloud

movements. Equations that are dominated by a large number of unknowns, such as cloud behaviors, contain chaotic situations at advanced levels since we are not able to predict instantaneous weather conditions sufficiently accurate. Thus, cloud-induced PV impact on voltage profiles is still at the top of the favorite topics in the literature.

In this thesis study, the effects of cloud-induced PV power on voltage profiles are investigated within the framework of three main case studies.

4.3 Case Studies and Results

All cases are based on the interruption in the solar radiance that caused by cloud movements between 14:00 and 14:01, when the solar radiation level is the highest (1000 W/m^2). Cases investigate the impacts of these interruptions on the load voltage levels. Since our microgrid is in islanded mode between 08:00 to 20:00, all of the simulations are run when microgrid is in islanded mode.

Base case: The base case forms the basis for the examination of the other cases and to reveal the differences between case studies. In this case, it is assumed that there is no BSS (Battery Storage System) in Building D and that the penetration of PV power drops from 100% to 0% in a minute. This case can be described as ‘full cloudy without BSS.’

Case 2: In this case, microgrid has BSS in the Building D when it is in islanded mode. This case type can be defined as ‘full cloudy with BSS.’

Case 3: In this case, four other sub cases with different PV penetrations are examined together with options with or without BSS in Building D.

4.3.1 Base Case: Full Cloudy without BSS

This case can be called the worst-case scenario for our microgrid design. In this case, it is assumed PV penetration level declines to 0% from 100% in a minute and there is no battery storage system in Building D. It is very rare that the PV penetration level in the real field reduces to 0% (maybe in case of breakdown or in very dense cloudy weather). However, it is important to consider even the worst-case scenario for the system design.

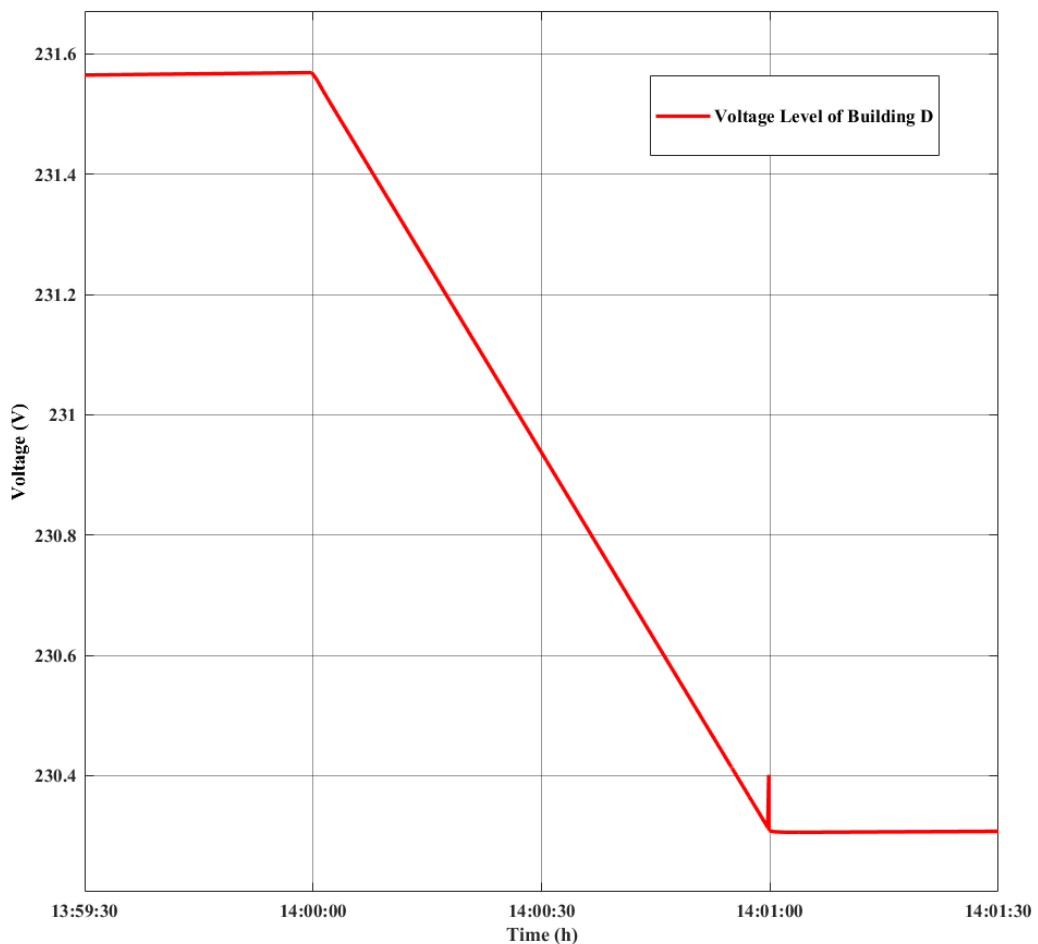

Figure 4.3.1.1 Voltage graph of Building D without BSS for the base case

The voltage graph of the Building D for 1 minute when the PV penetration level drops from 100% ($1000 W/m^2$) to 0% ($0 W/m^2$) is given in Figure 4.3.1.1. Also, in this case, it is assumed that there is no battery storage system in the Building D. As clearly can be seen from Figure 4.3.1.1, before cloud induced

PV impacts occur on voltage profiles, voltage level of the Building D forms a nearly constant profile around 231.55 V. When PV power starts to decline at 14:00, sudden decrease begins on the voltage level of the Building D. After the end of the drop in PV power, 1.26 V voltage decline actualizes in the voltage profile of the Building D. We must remember that when the microgrid switches to islanded mode responsibility of the continuation of the operation is belongs to the diesel generator so the reason of this decline not being more severe in the period of no grid connection is the powerful diesel generator in the Building J. This clearly shows even though Building D is the farthest building to the Building J, the diesel generator is able to prevent the voltage fluctuation. Also, the subsequent cases that we have performed will reveal the importance of Building D's 15 kW battery storage system.

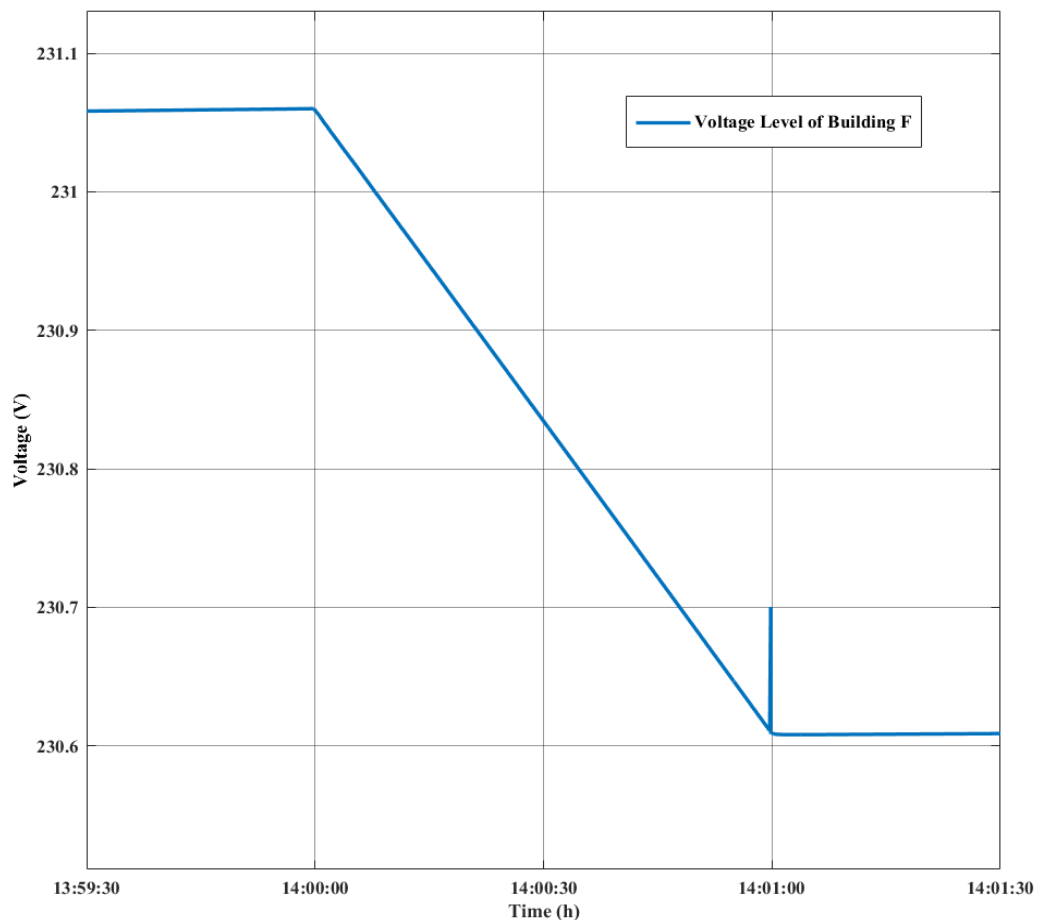

Figure 4.3.1.2 Voltage graph of Building F without BSS for the base case

The voltage graph of the Building F for 1 minute when the PV penetration level drops from 100% (1000 W/m^2) to 0% (0 W/m^2) is given in Figure 4.3.1.2. It should be noted that Building F is located between Buildings D and J. Also, Building F is the smallest building in the microgrid system. In this case, it is assumed that there is no battery storage system in the Building D.

Before voltage fluctuation occurs, the average voltage level of all of the phases is 231.07 V. Since the Building F is the smallest building and closer to the Building J, the diesel generator stops voltage decline at the 230.61 V, so the voltage decline in the Building F is 0.46 V.

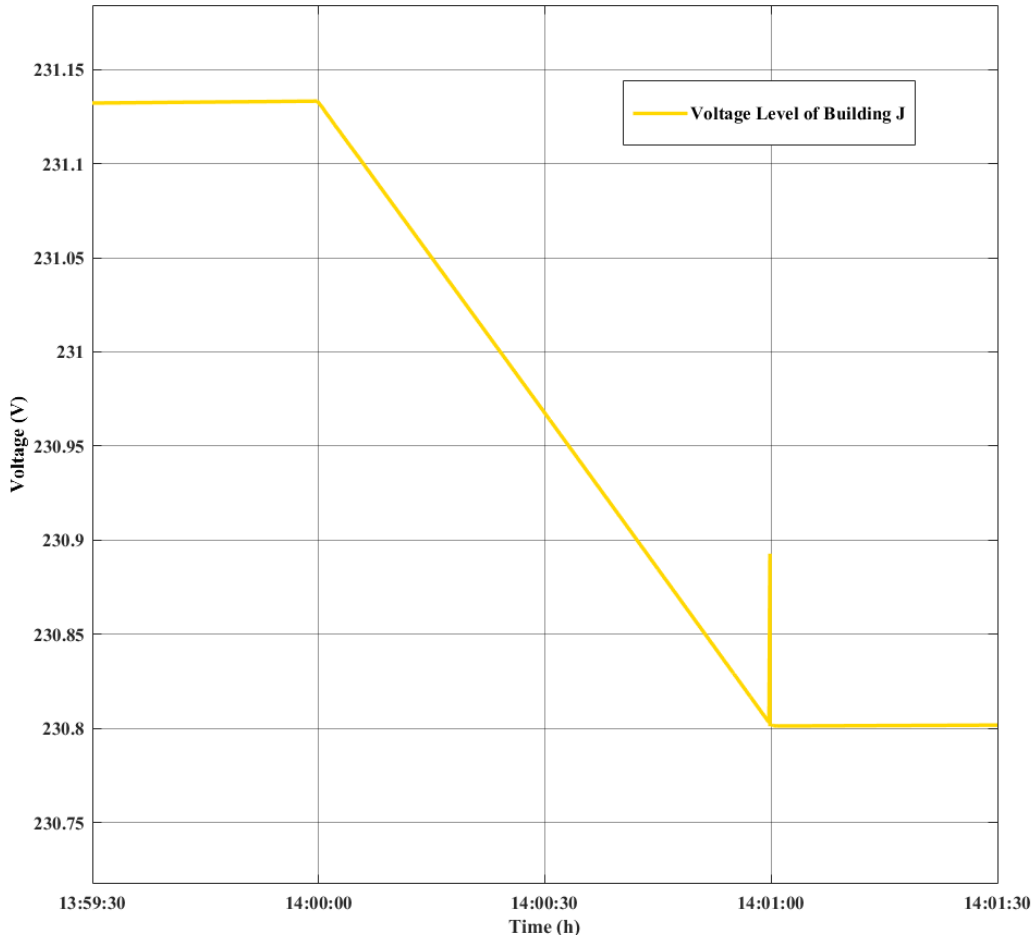

Figure 4.3.1.3 Voltage graph of Building J without BSS for the base case

The voltage graph of the Building J for 1 minute when the PV penetration level drops from 100% (1000 W/m^2) to 0% (0 W/m^2) is given in Figure 4.3.1.3. It

should be noted that Building J has the 500kVA diesel generator. In this case, it is assumed that there is no battery storage system in the Building D. 1 minute after the voltage drop start, the voltage level of the Building J decreases to the lowest value, until the diesel generator gives the adequate power to the grid. Before PV power declines, the voltage level is 231.13 V. The lowest voltage level seen during the analyzed time interval is 230.8 V. Voltage drop of 0.33 V occurs in Building J. As a result, since Building J has the diesel generator, the smallest voltage drop is experienced in this building.

To see results more clearly, Figure 4.3.1.4 gives the voltage drops in all buildings for the base case.

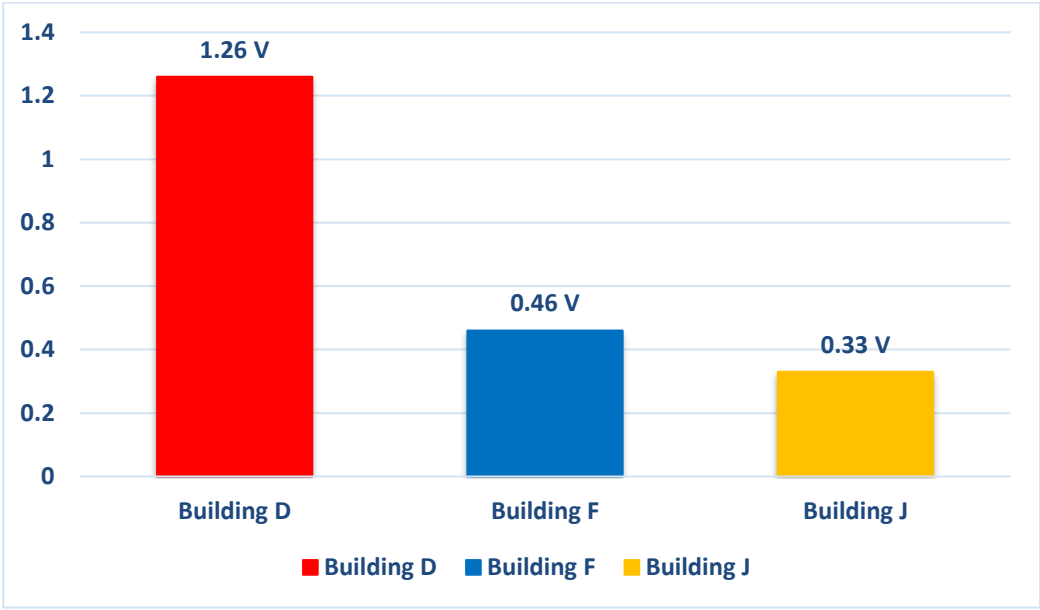

Figure 4.3.1.4 Voltage drops in buildings for the base case

4.3.2 Case 2: Full Cloudy with BSS

As in the base case, PV penetration level declines to 0% from 100% in a minute, however, unlike the base case, it is assumed that Building D has 15 kW battery system. Thus, in this case, the impact of the battery system in Building D on the voltage quality of other buildings is investigated.

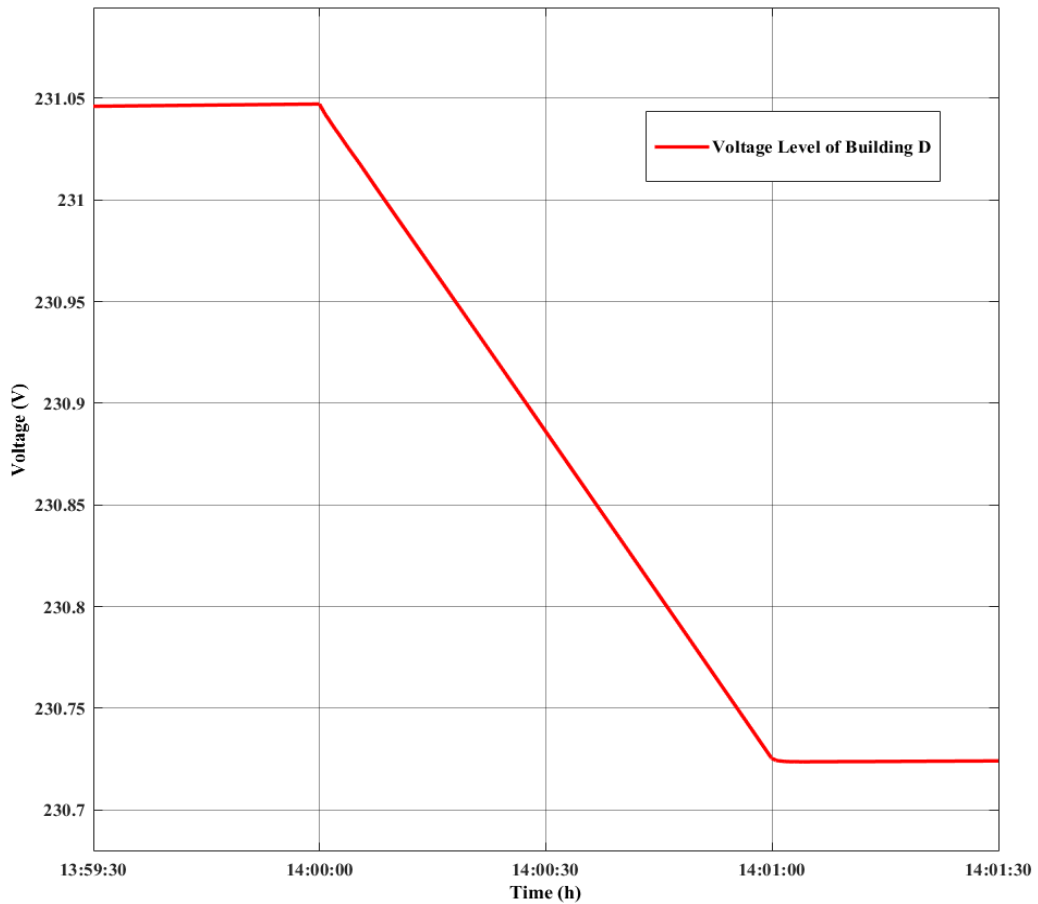

Figure 4.3.2.1 Voltage graph of Building D with BSS for case 2

The voltage graph of the Building D for 1 minute when the PV penetration level drops from 100% (1000 W/m^2) to 0% (0 W/m^2) is given in Figure 4.3.2.1. Also, in this case, it is assumed that there is a battery storage system in the Building D. As clearly can be seen from Figure 4.3.2.1, before cloud induced PV impacts occur on voltage profiles, voltage level of the Building D is around 231.05 V. When PV power starts to decline (from 21 kW to 0 kW) at 14:00, sudden decrease begins on the voltage level of the Building D. During this 1

minute interval, the maximum voltage fluctuation is 0.32 V. Additionally, compared to the previous case for Building D, even though Building D is the largest building in the 3DMicrogrid, a 15 kW battery storage system in Building D cause a recovery of 0.94 V in voltage drop level. Therefore, we can say that the 15 kW battery system is of great importance in terms of the voltage quality of Building D. In the next simulation results, we will examine the effect of the battery system on voltage levels in other buildings.

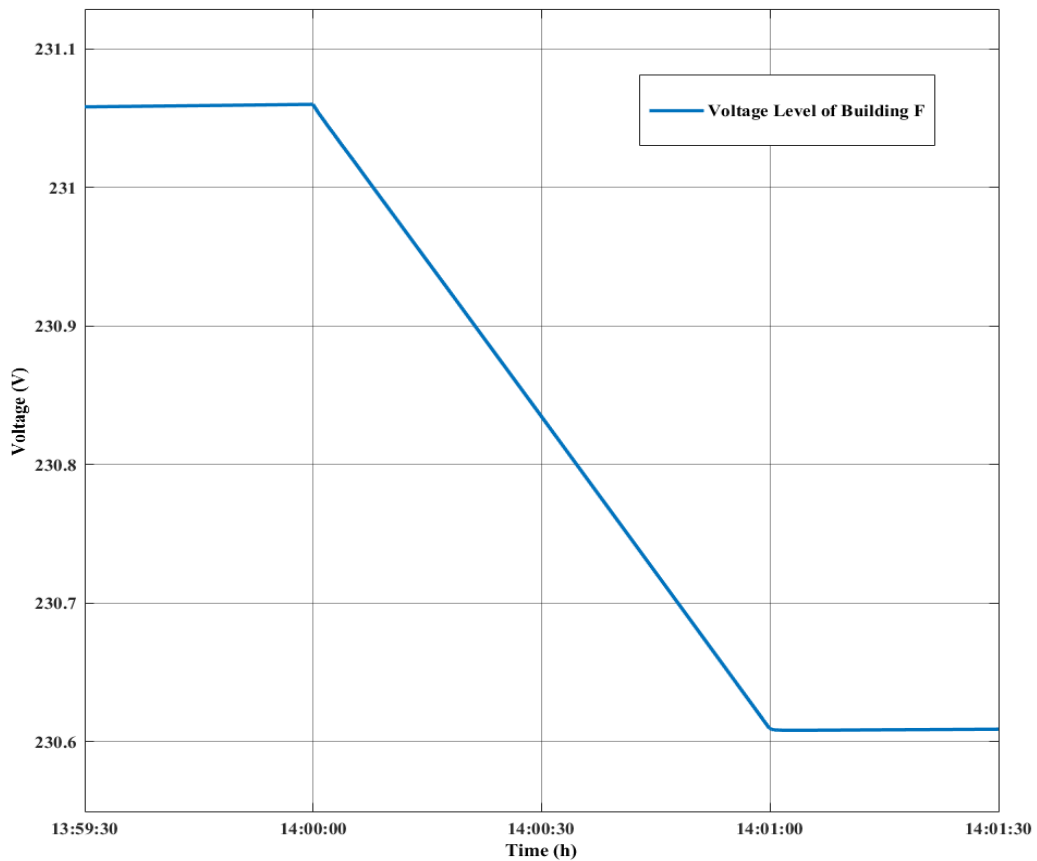

Figure 4.3.2.2 Voltage graph of Building F with BSS for case 2

The voltage graph of the Building F for 1 minute when the PV penetration level drops from 100% ($1000 W/m^2$) to 0% ($0 W/m^2$) is given in Figure 4.3.2.2. Also, in this case, it is assumed that there is a battery storage system in the Building D. Before voltage fluctuation occurs, average voltage level of all of the phases is 231.06 V. Since the Building F is the smallest building and closer to the Building J, the diesel generator stops voltage decline at the 230.61 V, so the voltage decline in the Building F is 0.45 V for case 2. There is only a 0.01 V

improvement in voltage profile compared to the previous case for Building F (without using a battery). As a result, it can be said clearly that the 15 kW BSS (Battery Storage System) used in the Building D has no effective role against the voltage problems experienced in the Building F. Also, clearly, diesel generator in the Building J has a really big impact on the voltage quality of Building F.

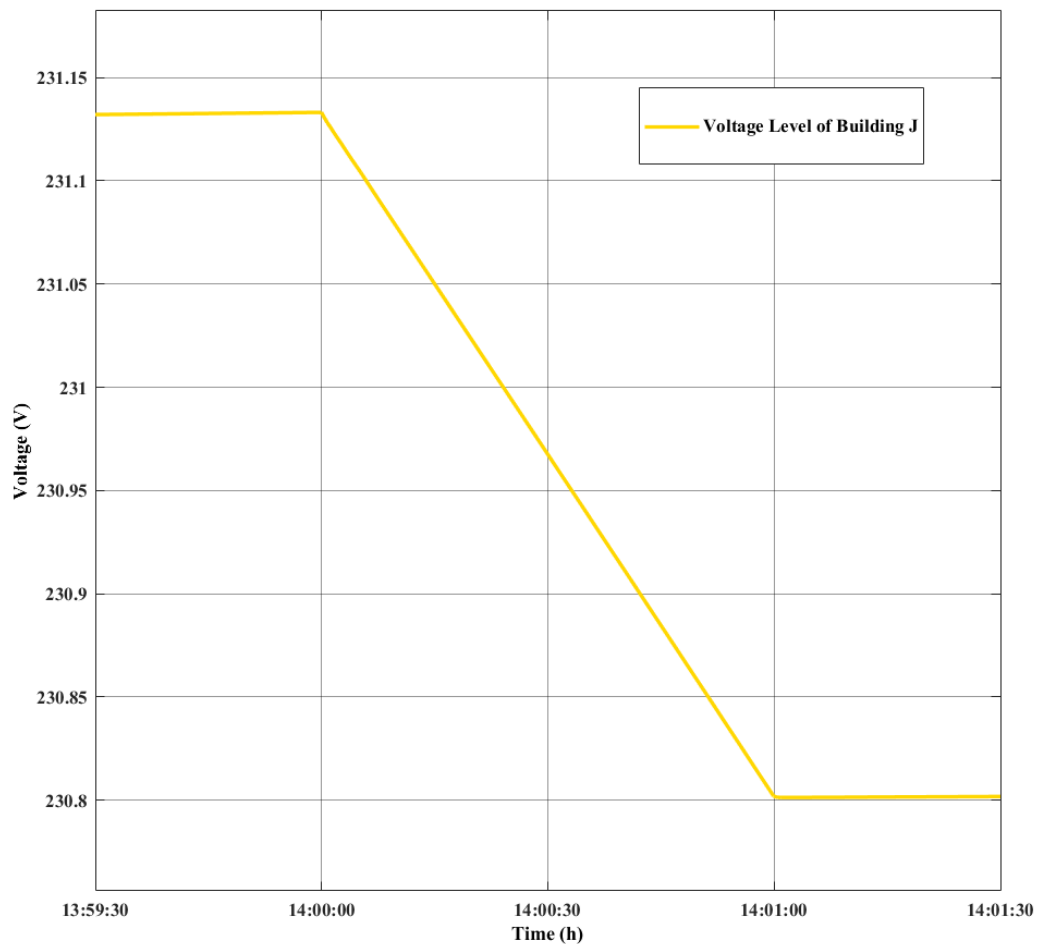

Figure 4.3.2.3 Voltage graph of Building J with BSS for case 2

The voltage graph of the Building J for 1 minute when the PV penetration level drops from 100% ($1000 \text{ W}/\text{m}^2$) to 0% ($0 \text{ W}/\text{m}^2$) is given in Figure 4.3.2.3. It should be remembered that Building J has the 500kVA diesel generator. Before PV power declines, the average voltage level of the all three phases is 231.13 V. The lowest voltage level seen during the analyzed time interval for all three

phases is 230.8 V. Thus, as in the base case, the maximum voltage fluctuation for Building J is still 0.33 V.

To see results more clearly, Figure 4.3.2.4 gives the voltage drop in all buildings for case 2.

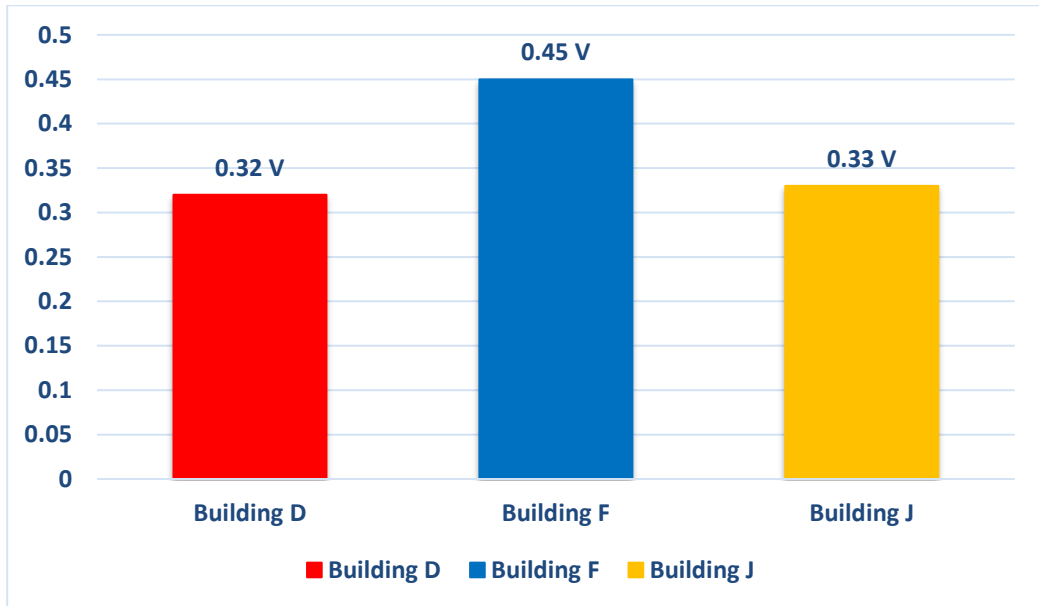

Figure 4.3.2.4 Voltage drops in buildings for the case 2

As a conclusion, it is clear, even though it may cause significant improvements in the voltage profile of Building D, the battery storage system in the Building D does not cause a sufficient performance improvement for the Building J and Building F. The most important reason why the battery does not reach a valid result in the J and F buildings is that the diesel generator located in the Building J plays a very active role when the Microgrid goes into the islanded mode, and the battery system apparently does not have enough power for the Building J and F.

4.3.3 Case 3

Case 3 examines the impacts of different penetration levels in PV power on the load voltage profiles with either battery or non-battery options. Four different PV penetration levels are investigated, these are 80%, 60%, 40%, and 20%, respectively.

4.3.3.1 Case 3: 80% PV Penetration

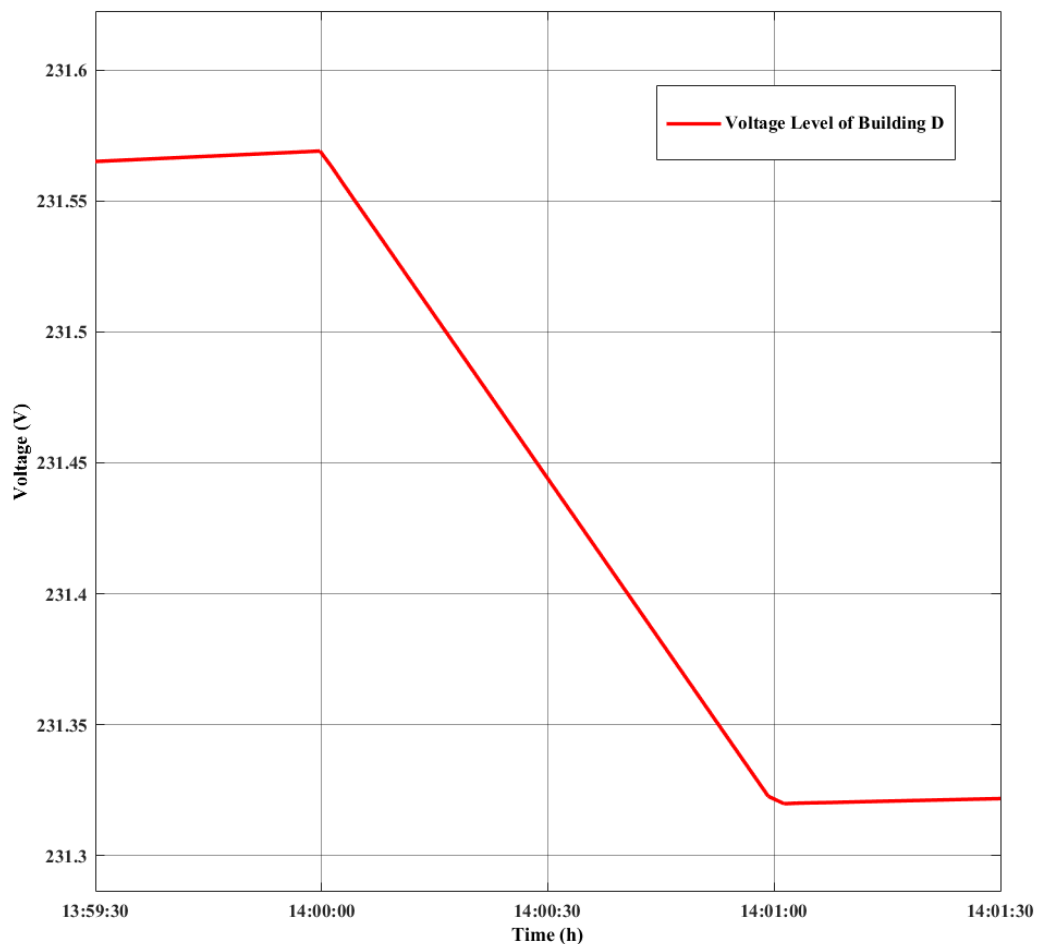

Figure 4.3.3.1.1 80% PV Penetration voltage graph of Building D without BSS

The voltage graph of the Building D for 1 minute when the PV penetration level drops from 100% ($1000 W/m^2$) to 80% ($800 W/m^2$) is given in Figure 4.3.3.1.1. Also, in this case, it is assumed that there is no battery storage system in the Building D. As clearly can be seen from Figure 4.3.3.1.1, before cloud

induced PV impacts occur on voltage profiles, voltage level of the Building D forms a nearly constant profile around 231.56 V. When voltage levels reach a stable profile, 0.24 V voltage decline actualizes in the voltage profile of the Building D. This clearly shows although Building D is the largest and farthest building to the Building J, the diesel generator is able to prevent the voltage fluctuation. In fact, a power loss of 20% (from 21 kW to 16.8 kW) is a condition that can be experienced frequently in solar systems and should not be a major problem for the microgrid system.

After all, it can easily be said that the 20% decrease in PV power would not make any significant differences in voltage levels.

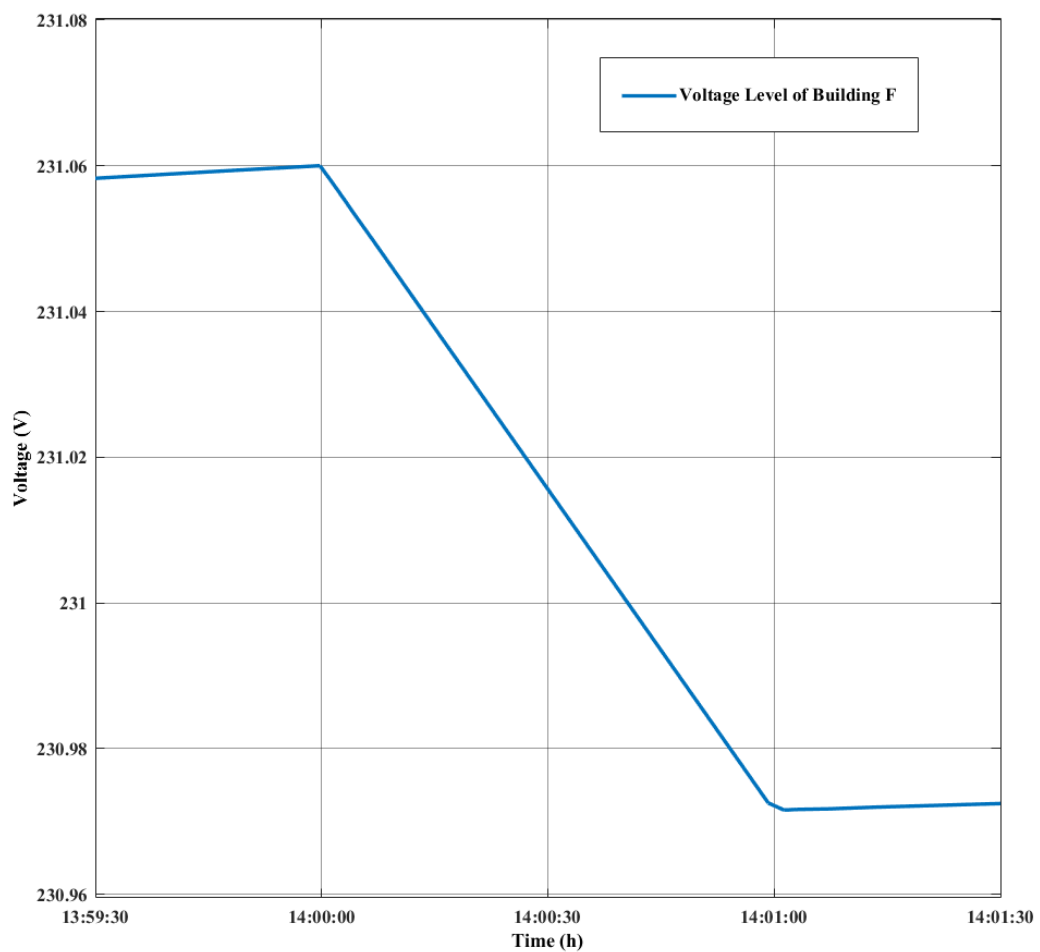

Figure 4.3.3.1.2 80% PV Penetration voltage graph of Building F without BSS

The voltage graph of the Building F for 1 minute when the PV penetration level drops from 100% (1000 W/m^2) to 80% (800 W/m^2) is given in Figure 4.3.3.1.2. In this case, it is assumed that there is no battery storage system in the Building D.

Before voltage fluctuation occurs, average voltage level of all of the phases is 231.06 V. The maximum voltage fluctuation observed for the Building F in the analyzed time interval is 0.09 V. Just like case for the Building D, 20% drop in PV power does not have any adverse effects on the voltage level of the Building F.

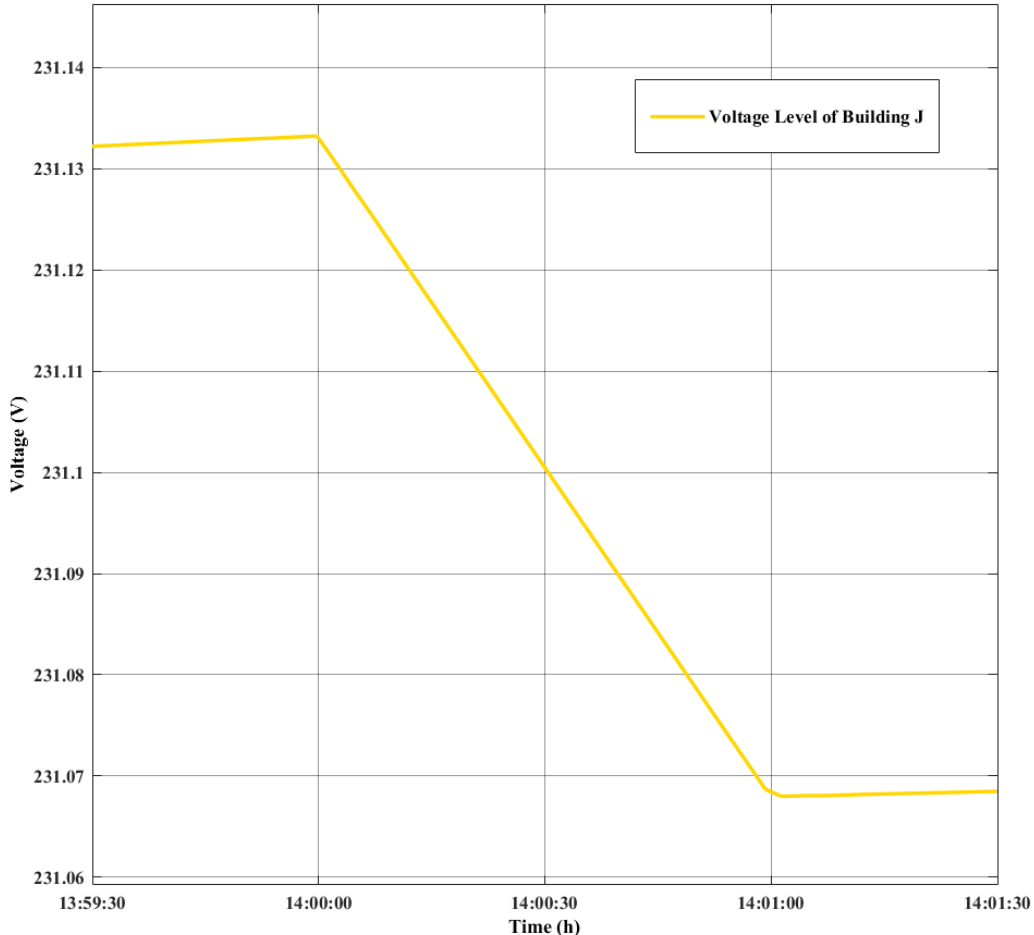

Figure 4.3.3.1.3 80% PV Penetration voltage graph of Building J without BSS

The voltage graph of the Building J for the 1-minute interval when the PV power drops from 100% to 80% (from 21 kW to 16.8 kW) is given in Figure

4.3.3.1.3. Also, in this case, it is assumed that there is no battery system in the Building D. The maximum voltage decline seen during the analyzed time interval for all three phases is 0.06 V. Since the diesel generator is at the master position in islanded mode, it is unlikely to observe a noticeable drop in the voltage level of the Building J.

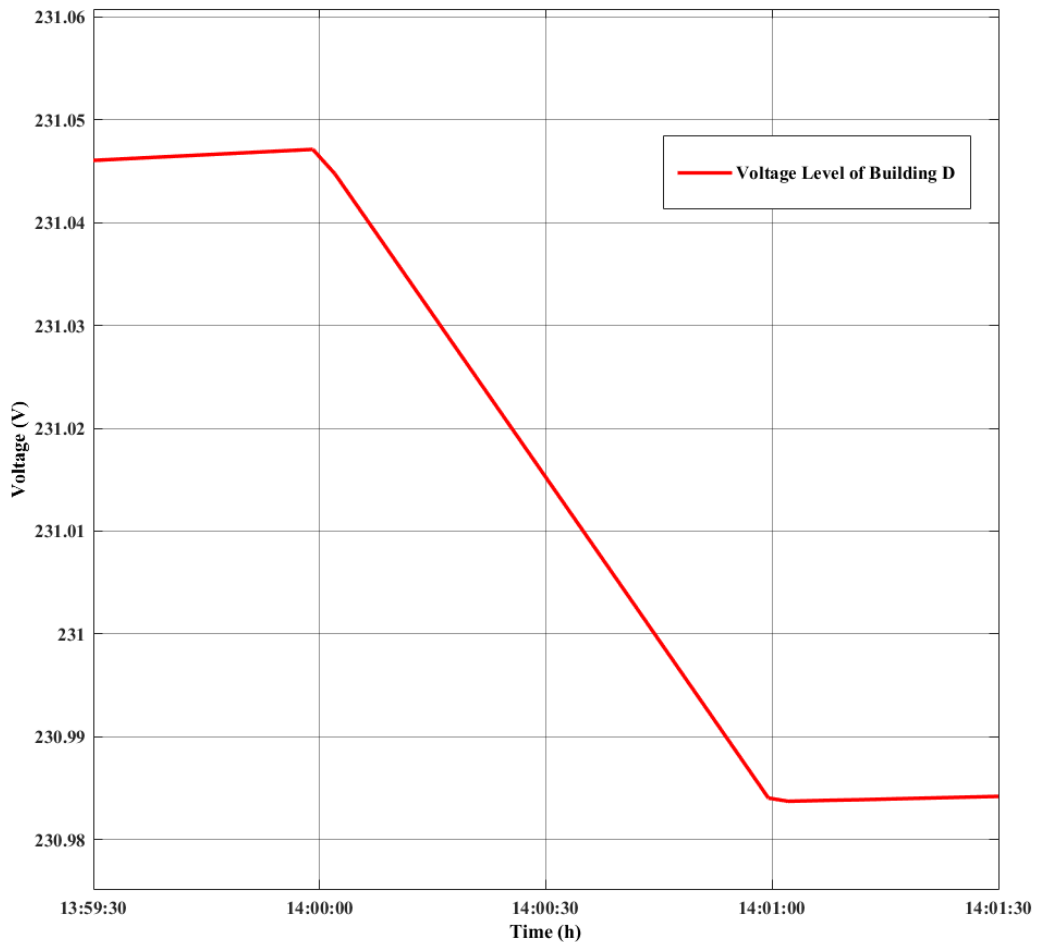

Figure 4.3.3.1.4 80% PV Penetration voltage graph of Building D with BSS

The voltage graph of the Building D for 1 minute when the PV penetration level drops from 100% (1000 W/m^2) to 80% (800 W/m^2) is given in Figure 4.3.3.1.4. Also, in this case, it is assumed that there is a battery storage system in the Building D. As clearly can be seen from Figure 4.3.3.1.4, before cloud induced PV impacts occur on voltage profiles, voltage level of the Building D is around 231.05 V. During this 1 minute interval, the maximum voltage

fluctuation is 0.06 V. The maximum voltage fluctuation observed during 10-minutes period in this phase is 0.1 V. It should be remembered that for the case that the battery in Building D is removed from the system, a voltage drop is 0.24 V, so battery storage system makes 0.18 V improvement on the voltage quality of this building for this case.

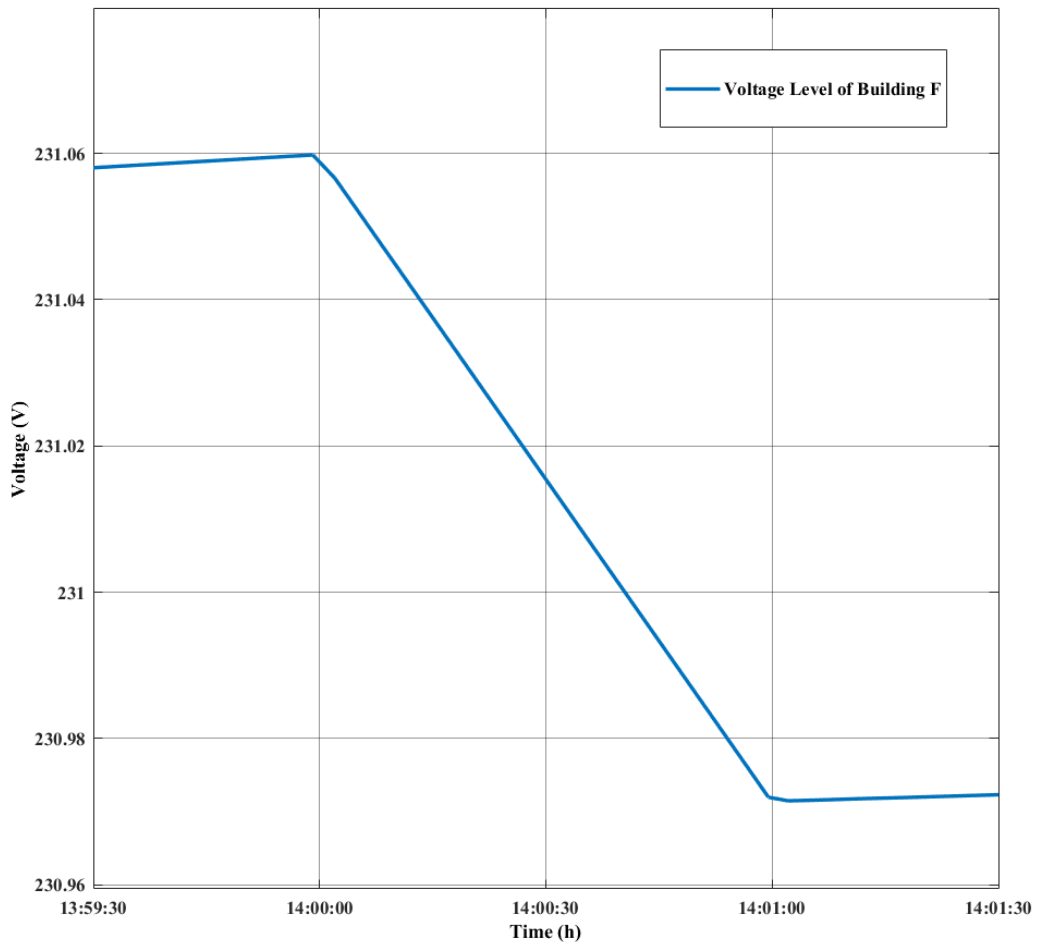

Figure 4.3.3.1.5 80% PV Penetration voltage graph of Building F with BSS

The voltage graph of the Building F for 1 minute when the PV penetration level drops from 100% (1000 W/m^2) to 80% (800 W/m^2) is given in Figure 4.3.3.1.5. Also, in this case, it is assumed that there is a battery storage system in the Building D. The diesel generator is so dominant for this building than the battery system. The difference is only 0.01 V between with and without battery options.

As a result, it can be said that the 15 kW BSS (Battery Storage System) used in the Building D has no effective role against the voltage problems experienced in the Building F. Also, clearly, diesel generator in the Building J has a tremendous impact on the voltage quality of Building F.

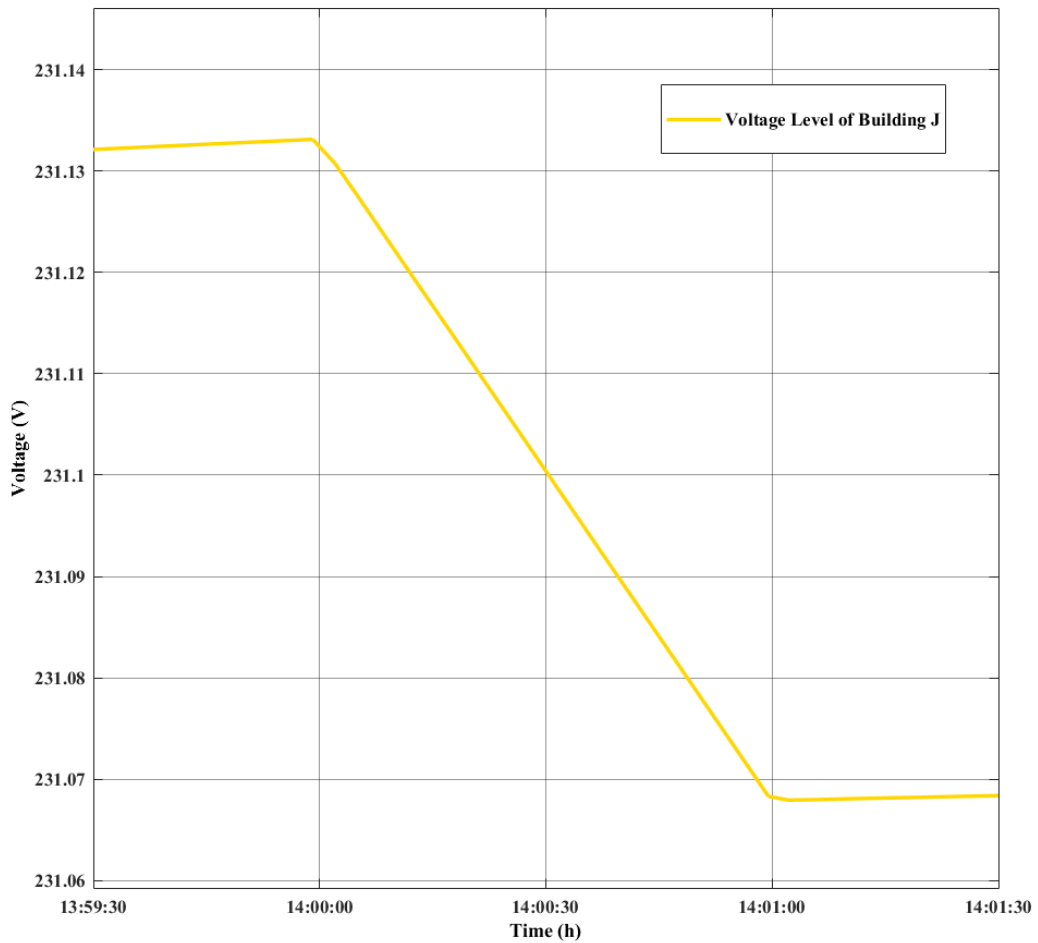

Figure 4.3.3.1.6 80% PV Penetration voltage graph of Building J with BSS

The voltage graph of the Building J for the 1-minute interval when the PV power drops from 100% to 80% (from 21 kW to 16.8 kW) is given in Figure 4.3.3.1.6. Also, in this case, it is assumed that there is a battery system in the Building D. The maximum voltage fluctuation for Building J is still around 0.06 V. As mentioned before, when microgrid works in islanded mode, the diesel generator is at the master position. Therefore, it is unlikely to observe a noticeable voltage drop for 80% penetration level.

To see results more clearly, Figure 4.3.3.1.7 gives the voltage drops in all buildings for the 80% penetration.

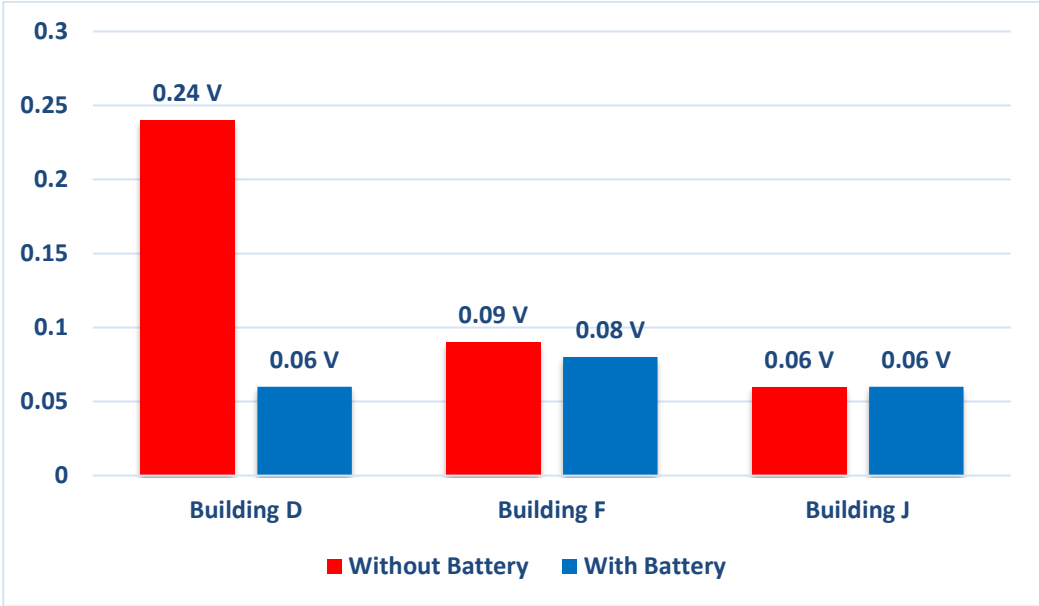

Figure 4.3.3.1.7 Voltage drops in buildings for the 80% penetration level

As a conclusion, since the 20% power drop is not a significant danger to the system, as in the some of the previous results, it is clear that the energy storage system in the Building D does not cause a sufficient voltage quality improvement for the buildings. Also, the diesel generator located in the Building J plays a very active role in the islanded mode.

4.3.3.2 Case 3: 60% PV Penetration

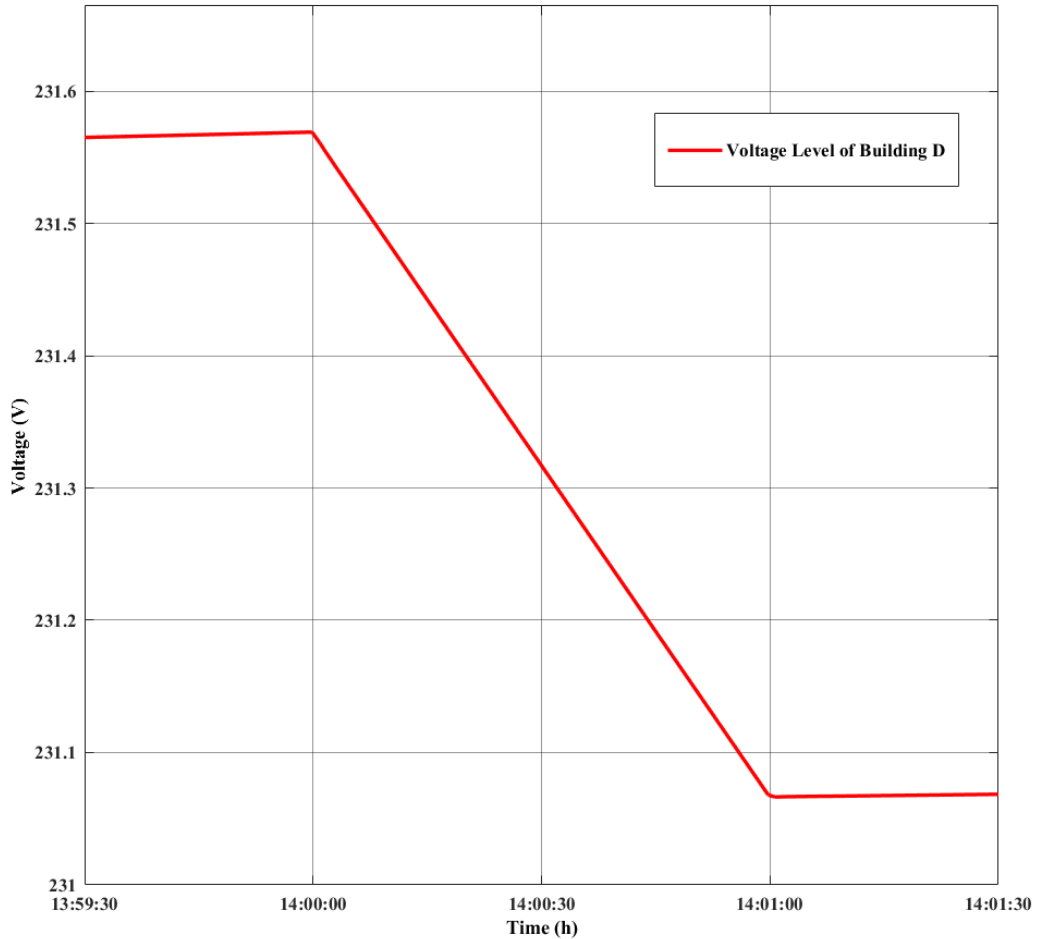

Figure 4.3.3.2.1 60% PV Penetration voltage graph of Building D without BSS

The voltage graph of the Building D for 1 minute when the PV penetration level drops from 100% ($1000 W/m^2$) to 60% ($600 W/m^2$) is given in Figure 4.3.3.2.1. Also, in this case, it is assumed that there is no battery storage system in the Building D. As clearly can be seen from Figure 4.3.3.2.1, while PV power drops from 21 kW to 12.6 kW, 0.5 V voltage drop occurs in the voltage level of the Building D between 14:00 and 14:01. This clearly shows compared to the previous case (80% Penetration), the extra power loss of 4.2 kW increased the voltage drop from 0.26 V to 0.5 V. In fact, a power loss of 40% is a condition that can be experienced frequently in solar systems and should not be a major problem for the microgrid system.

As a conclusion, it is clear that the 40% drop in PV penetration level (from 100% to 60%) will only lead to an insignificant reduction in the voltage levels.

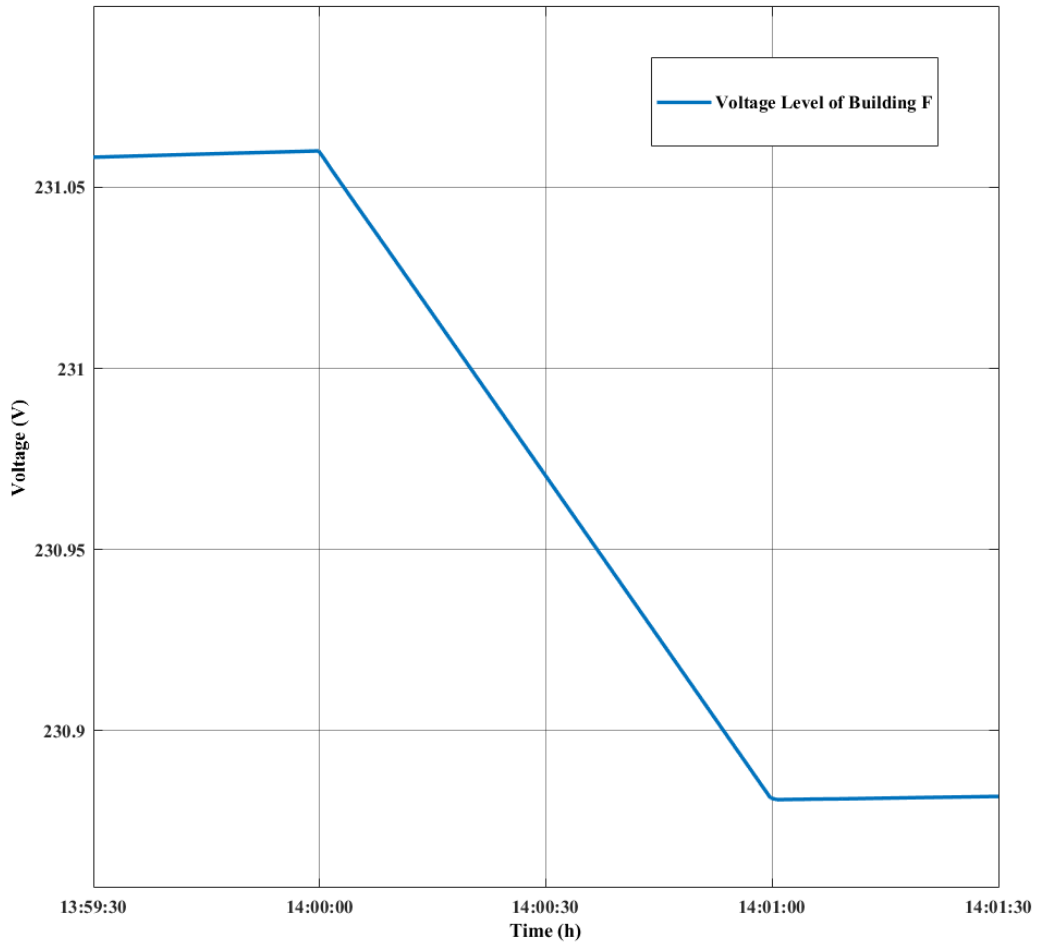

Figure 4.3.3.2.2 60% PV Penetration voltage graph of Building F without BSS

The voltage graph of the Building F for 1 minute when the PV penetration level drops from 100% (1000 W/m^2) to 60% (600 W/m^2) is given in Figure 4.3.3.2.2. In this case, it is assumed that there is no battery storage system in the Building D. Before voltage fluctuation occurs, the average voltage level of all of the phases is 231.06 V. The voltage level declines to 230.88 for the Building F between 14:00 and 14:01. Thus, the voltage drop is 0.18 V. Since Building F is the smallest building in the microgrid and close to the diesel generator in Building J, 40% drop in PV power does not have big impacts on the voltage level of the Building F.

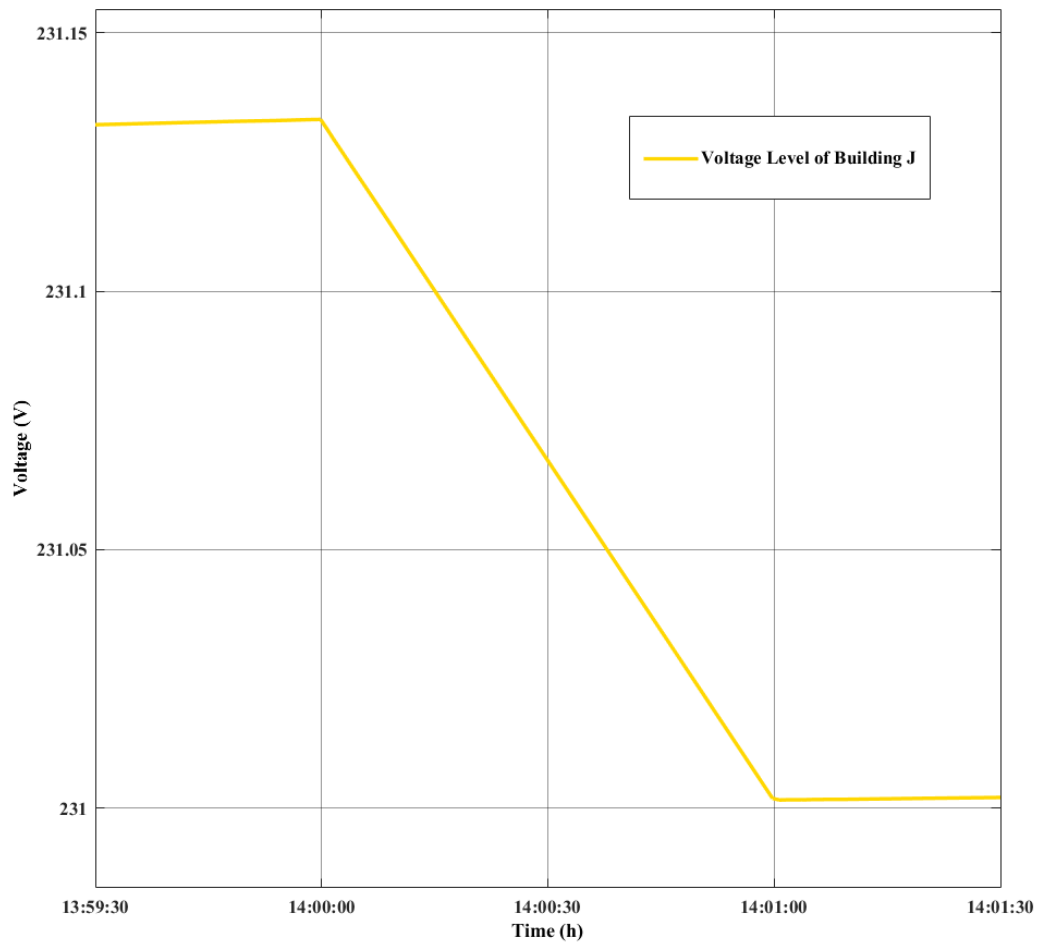

Figure 4.3.3.2.3 60% PV Penetration voltage graph of Building J without BSS

The voltage graph of the Building J for the 1-minute interval when the PV power drops from 100% to 60% (from 21 kW to 12.6 kW) is given in Figure 4.3.3.2.3. Also, in this case, it is assumed that there is no battery system in the Building D. The voltage drop seen for all three phases between 14:00 and 14:01 is 0.13 V. Since Building J has the 500 kVA diesel generator, it is unlikely to observe a noticeable drop in the voltage level of the Building J.

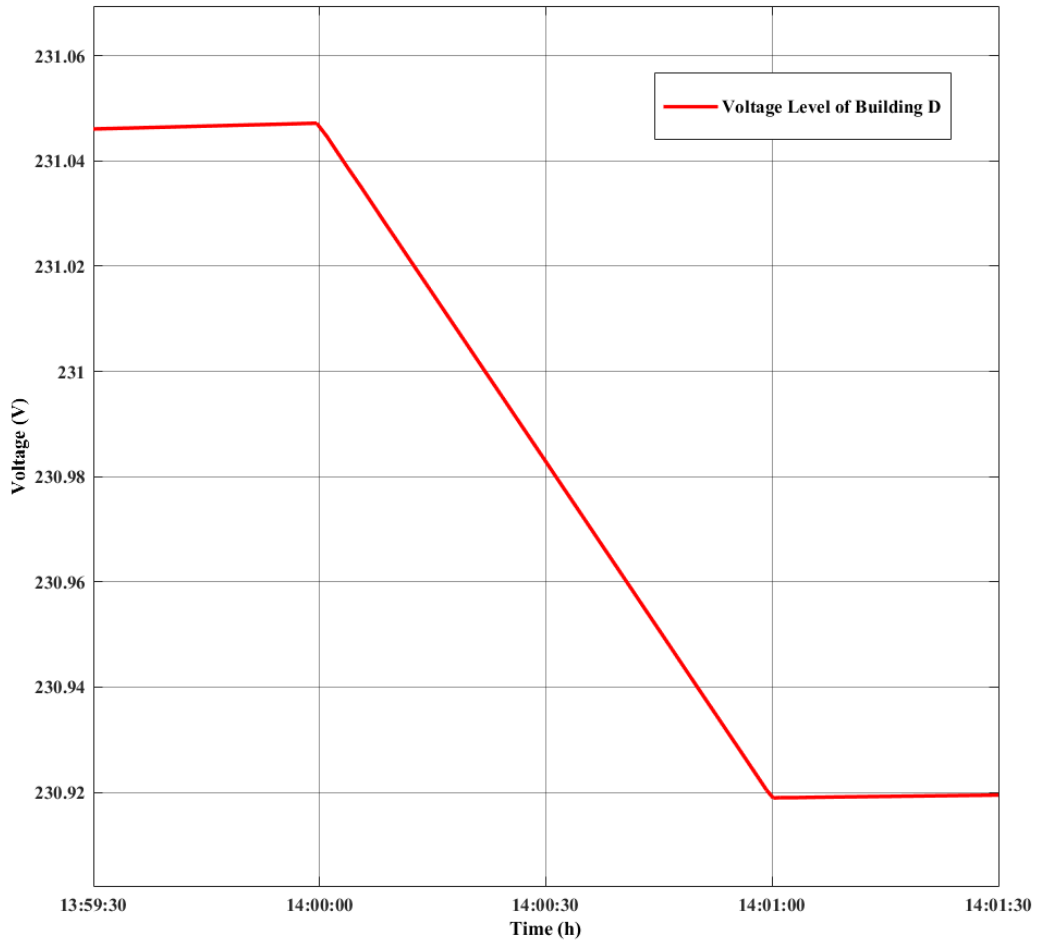

Figure 4.3.3.2.4 60% PV Penetration voltage graph of Building D with BSS

The voltage graph of the Building D for 1 minute when the PV penetration level drops from 100% (1000 W/m^2) to 60% (600 W/m^2) is given in Figure 4.3.3.2.4. Also, in this case, it is assumed that there is a battery storage system in the Building D. As clearly can be seen from Figure 4.3.3.2.4, when the battery in Building D is activated the voltage drop of 0.5 V diminished to 0.13 V. The battery therefore provides a recovery of 0.37 V in the average voltage profile. However, given the voltage standards, even 0.5 V voltage drop isn't important.

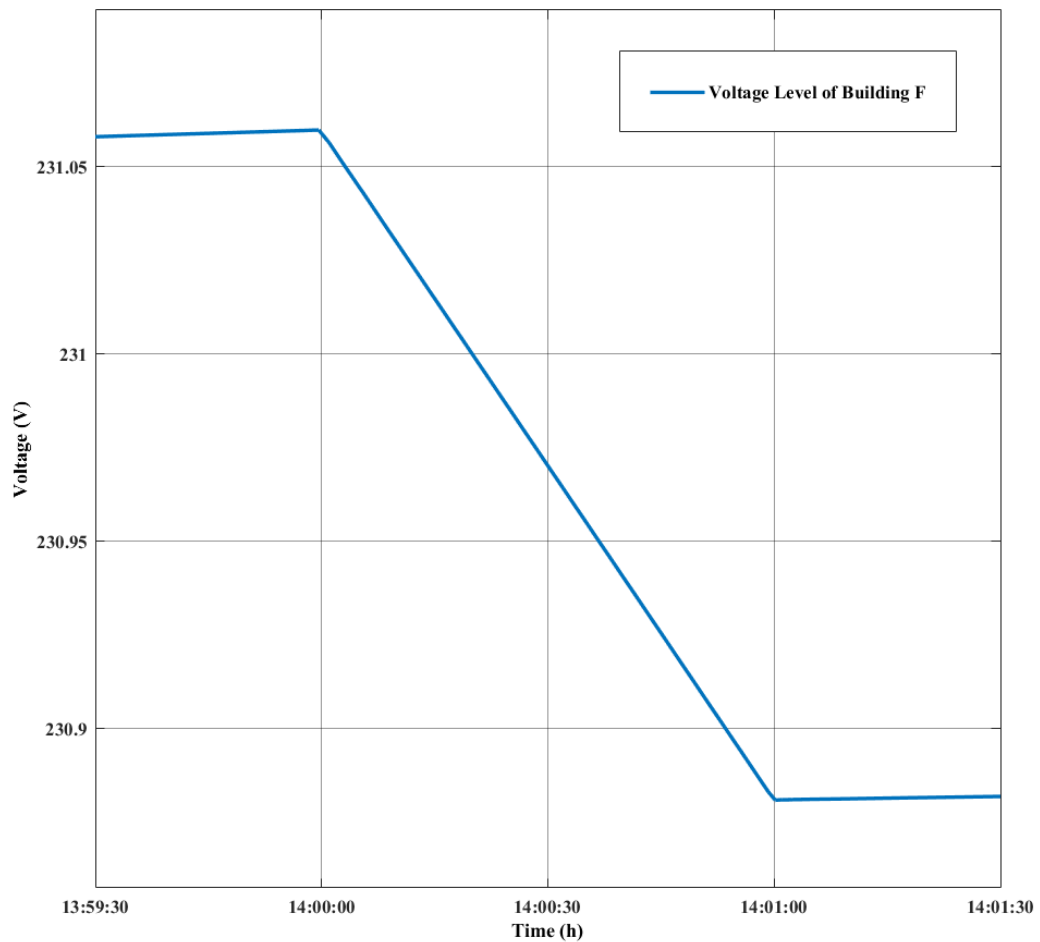

Figure 4.3.3.2.5 60% PV Penetration voltage graph of Building F with BSS

The voltage graph of the Building F for 1 minute when the PV penetration level drops from 100% (1000 W/m^2) to 60% (600 W/m^2) is given in Figure 4.3.3.2.5. Also, in this case, it is assumed that there is a battery storage system in the Building D. Since Building F is located between Building D and Building J, it takes advantage of the battery storage system in Building D and diesel generator in Building J. However, because the generator is very powerful in the islanded mode, the power supplied by the diesel generator can easily suppress impact of the battery storage system.

As a result, as in previous cases, it can be said that the 15 kW BSS (Battery Storage System) in Building D has no dominant role in the voltage problems of the Building F.

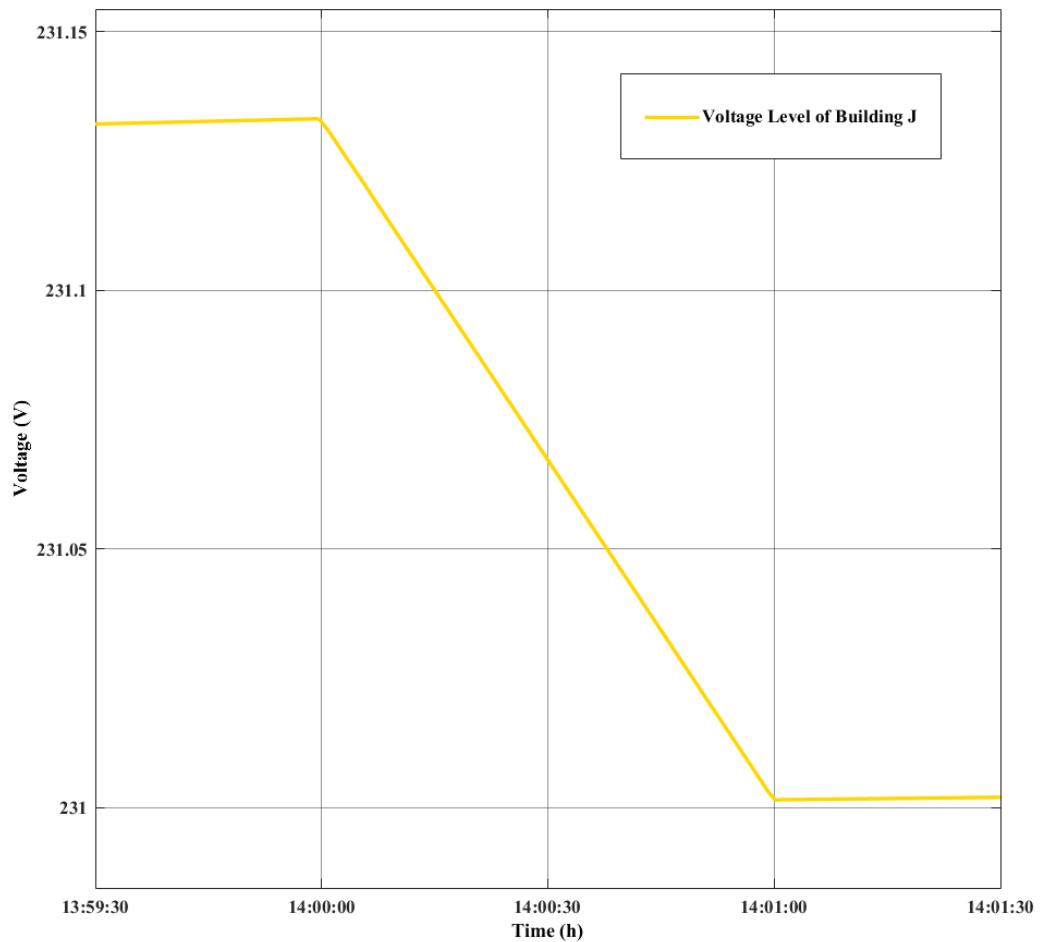

Figure 4.3.3.2.6 60% PV Penetration voltage graph of Building J with BSS

The voltage graph of the Building J for the analyzed 1-minute interval when the PV power drops from 100% to 60% (from 21 kW to 12.6 kW) is given in Figure 4.3.3.2.6. Also, in this case, it is assumed that there is a battery system in the Building D. The voltage drop is still 0.13 V for this building. It is clear that diesel generator in Building J is at the master position when microgrid works in islanded mode. Thus, as in previous cases, in Building J, there are no voltage drop differences for battery and battery-free options.

To see results more clearly, Figure 4.3.3.2.7 gives the voltage drops in all buildings for the 60% penetration.

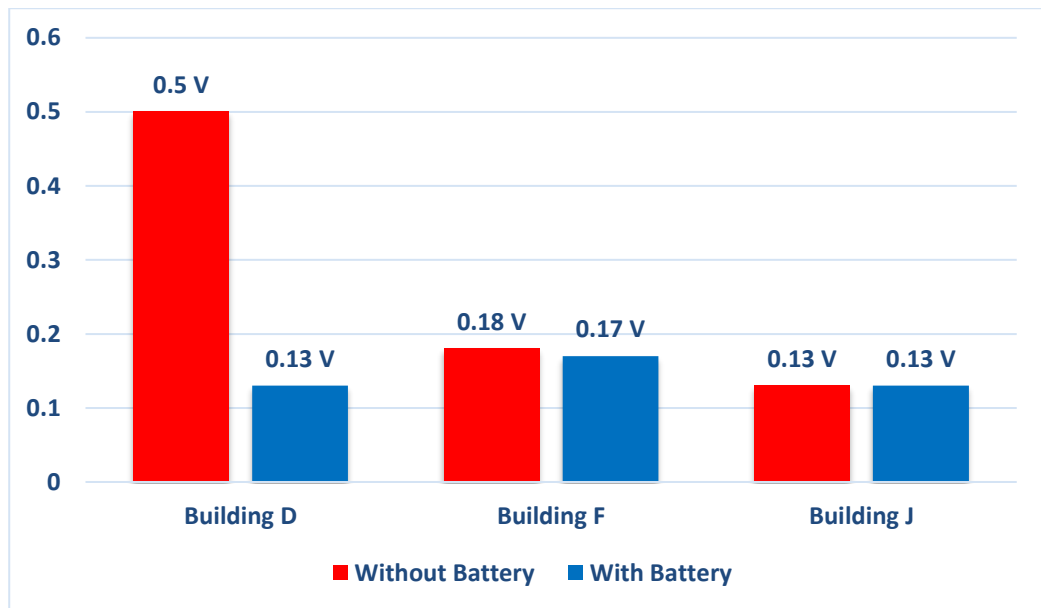

Figure 4.3.3.2.7 Voltage drops in buildings for the 60% penetration level

As a conclusion, the battery storage system in the Building D does not cause a useful voltage quality improvement for the Building J and Building F. However, the BSS makes 0.37 V improvement in the voltage level of the Building D.

4.3.3.3 Case 3: %40 PV Penetration

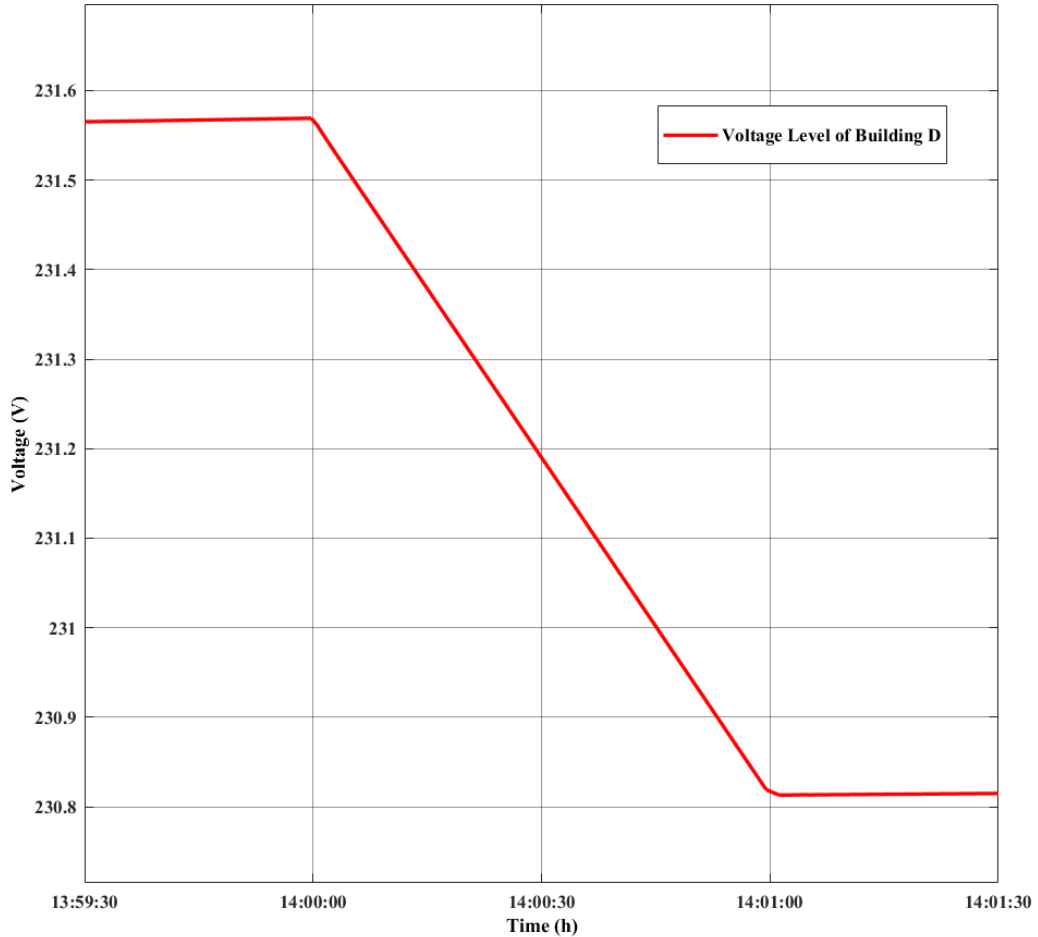

Figure 4.3.3.3.1 40% PV Penetration voltage graph of Building D without BSS

The voltage graph of the Building D for 1 minute when the PV penetration level drops from 100% ($1000 W/m^2$) to 40% ($400 W/m^2$) is given in Figure 4.3.3.3.1. Also, in this case, it is assumed that there is no battery storage system in the Building D. As clearly can be seen from Figure 4.3.3.3.1, while PV power drops from 21 kW to 8.4 kW, 0.75 V voltage drop occurs in the voltage level of the Building D between 14:00 and 14:01. Thus, compared to the previous case (60% Penetration), the voltage loss increases to 0.5 V from 0.75 V. Although there is a 60% voltage loss, there is still no significant drop in voltage levels. Of course, the contribution of diesel generator in Building J to voltage levels is very important and should not be forgotten.

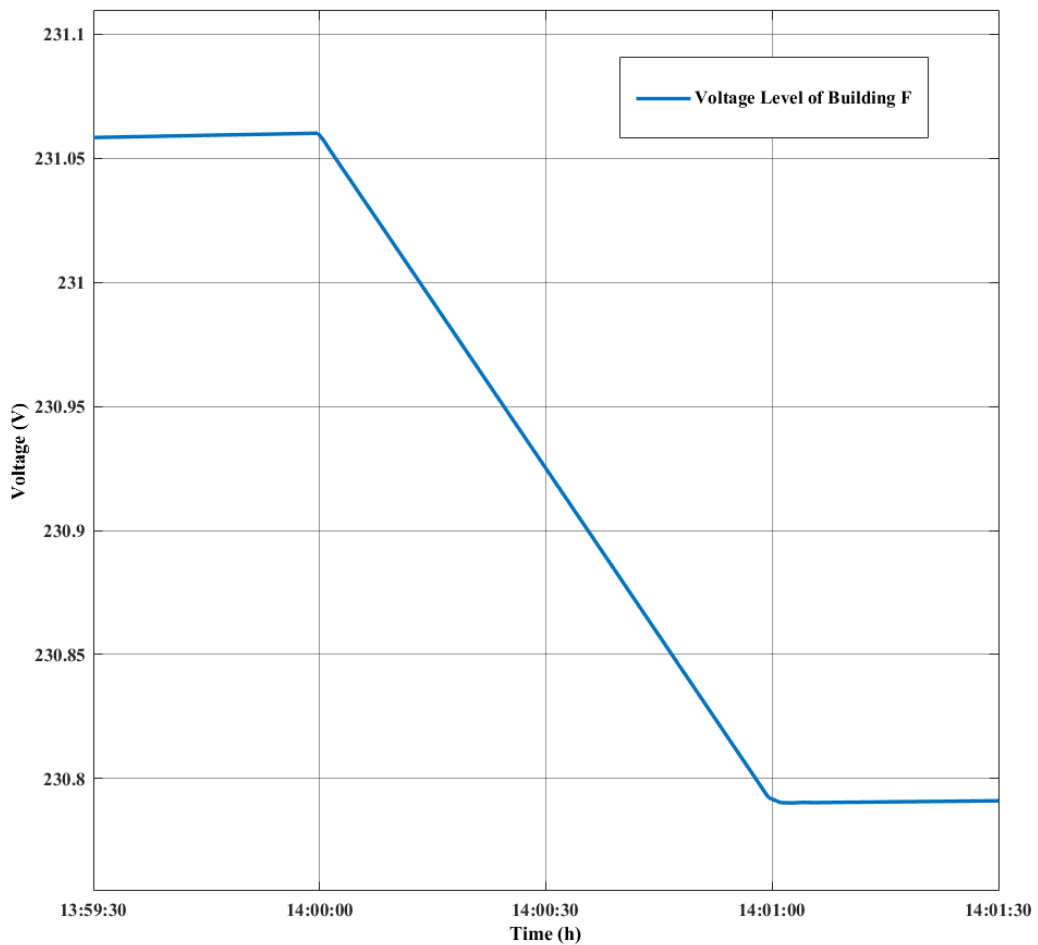

Figure 4.3.3.3.2 40% PV Penetration voltage graph of Building F without BSS

The voltage graph of the Building F for 1 minute when the PV penetration level drops from 100% (1000 W/m^2) to 40% (400 W/m^2) is given in Figure 4.3.3.3.2. In this case, it is assumed that there is no battery storage system in the Building D. Before voltage fluctuation occurs, the average voltage level is 231.06 V. The voltage level declines to 230.79 for the Building F between 14:00 and 14:01. Thus, the voltage drop is 0.27 V. Since Building F is close to the diesel generator in Building J, drop in PV power still does not have big impacts on the voltage level of the Building F.

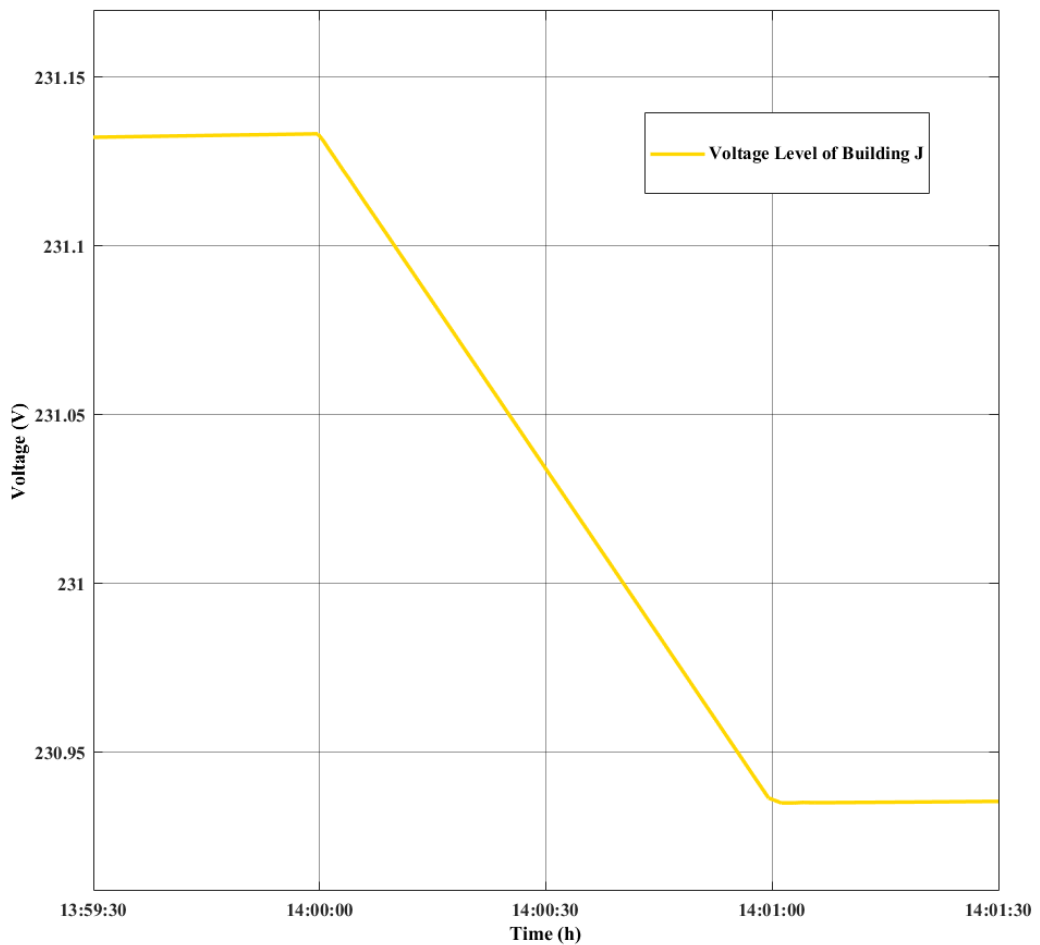

Figure 4.3.3.3.3 40% PV Penetration voltage graph of Building J without BSS

The voltage graph of the Building J for the 1-minute interval when the PV power drops from 100% to 40% (from 21 kW to 8.4 kW) is given in Figure 4.3.3.3.3. Also, in this case, it is assumed that there is no battery system in the Building D. The voltage drop seen for all three phases between 14:00 and 14:01 is 0.2 V. Since Building J has the 500 kVA diesel generator, a significant decrease in voltage levels of this building is not expected.

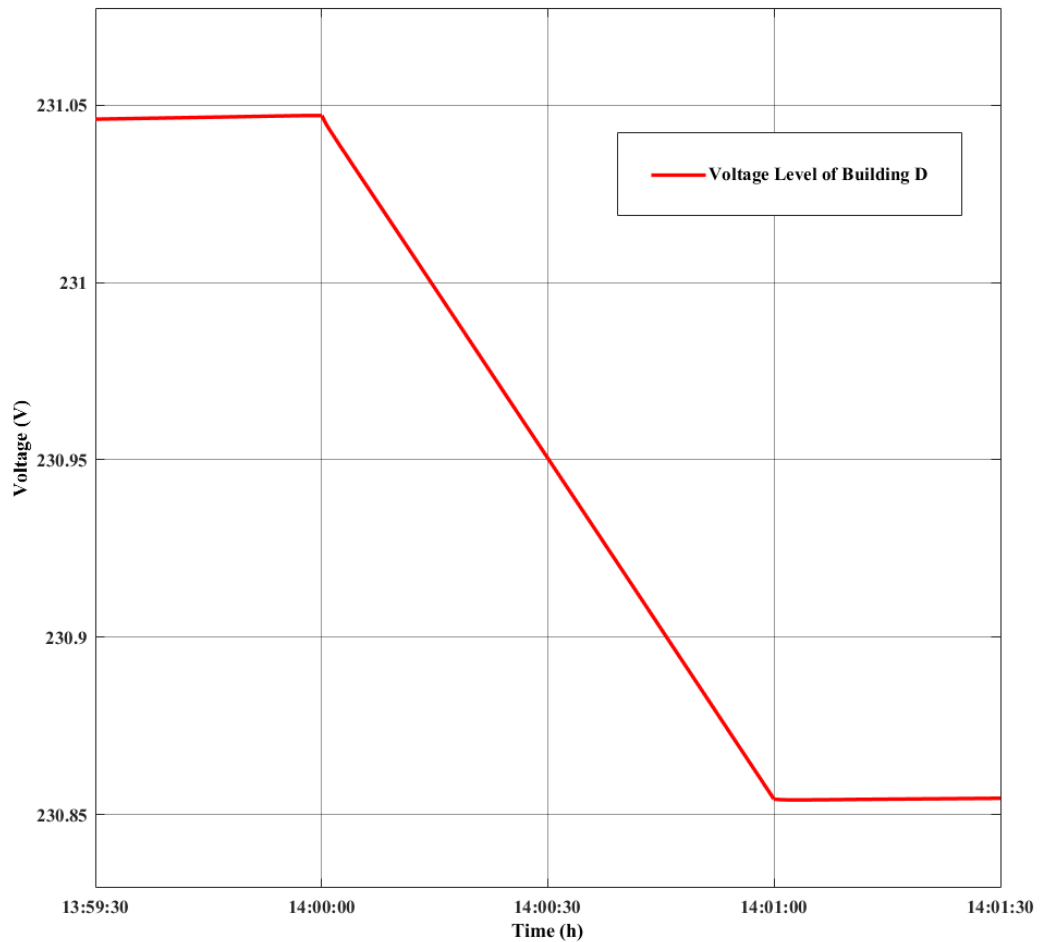

Figure 4.3.3.3.4 40% PV Penetration voltage graph of Building D with BSS

The voltage graph of the Building D for 1 minute when the PV penetration level drops from 100% (1000 W/m^2) to 40% (400 W/m^2) is given in Figure 4.3.3.3.4. Also, in this case, it is assumed that there is a battery storage system in the Building D. As clearly can be seen from Figure 4.3.3.3.4, when the battery storage is in the system, the amount of voltage drop in Building D decreased from 0.75 V to 0.19 V. Thus, battery system provides an improvement of 0.56 V for voltage levels. As the amount of power loss increases, the role of the battery on the voltage quality of Building D is gaining importance.

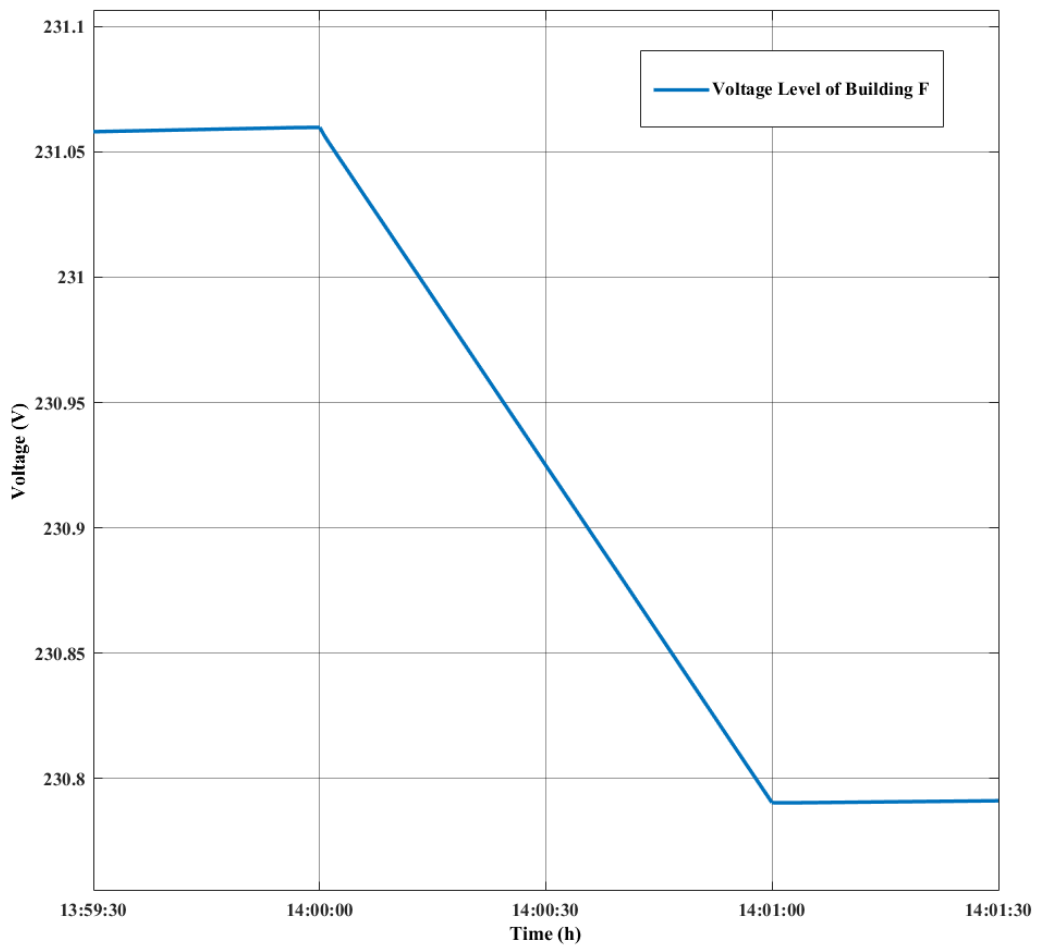

Figure 4.3.3.3.5 40% PV Penetration voltage graph of Building F with BSS

The voltage graph of the Building F for 1 minute when the PV penetration level drops from 100% (1000 W/m^2) to 40% (400 W/m^2) is given in Figure 4.3.3.3.5. Also, in this case, it is assumed that there is a battery storage system in the Building D. As already mentioned, this building takes advantage of the battery storage system in Building D and diesel generator in Building J. However, as previously experienced in the other cases, diesel generator plays a very dominant role on the voltage levels of Building F. For this reason, there is an insignificant difference between battery and battery-free cases such as 0.01 V. Thus, the 15 kW BSS (Battery Storage System) in the Building D does not have any positive impact on the voltage profile of Building F.

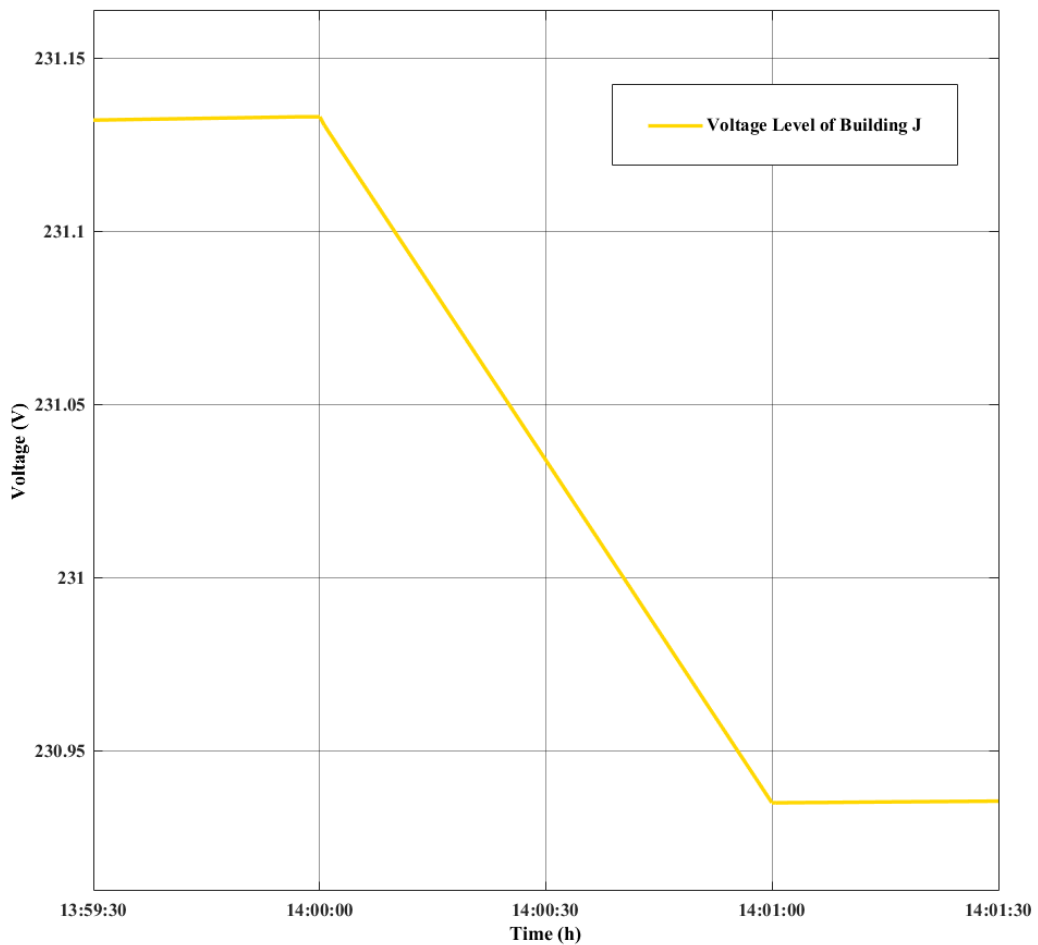

Figure 4.3.3.3.6 40% PV Penetration voltage graph of Building J with BSS

The voltage graph of the Building J for the analyzed 1-minute interval when the PV power drops from 100% to 40% (from 21 kW to 8.4 kW) is given in Figure 4.3.3.3.6. Also, in this case, it is assumed that there is a battery system in the Building D. Before voltage decline occurs voltage level of this building is 231.13 V. Until the voltage level reaches a stable profile, voltage of this building decreases to 230.93 V. It means voltage drop is still 0.2 V for this building. As in other cases, the minimum voltage drop happens in Building J, since diesel generator is so powerful in microgrid design.

To see results more clearly, Figure 4.3.3.3.7 gives the voltage drops in all buildings for the 40% penetration.

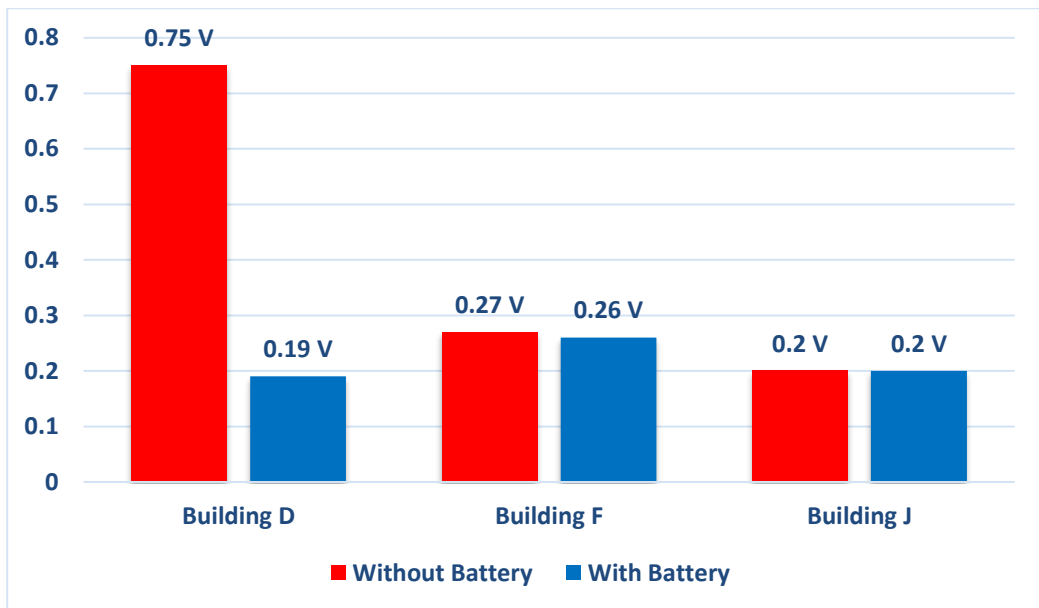

Figure 4.3.3.3.7 Voltage drops in buildings for the 40% penetration level

As a conclusion, the battery storage system in the Building D does not cause an effective voltage quality improvement for the Building J and Building F. However, the battery system makes a 0.62 V improvement in the voltage level of the Building D. Thus, the power of the battery is only enough to improve the voltage quality of the Building D. Also, it is clear from the results that 60% drop (from %100 to %40) in PV penetration does not cause significant adverse effects on the voltage profiles of the buildings.

4.3.3.4 Case 3: 20% PV Penetration

Compared to other cases, the 20% PV penetration level scenario is one of the most dangerous among the scenarios that can be often encountered in the real field. Especially in cloudy weather conditions, this kind of low penetration levels can happen even in seconds and these ups and downs in PV power output can cause serious damages to especially customer's electronic devices. In this case, the voltage levels of the buildings are examined below.

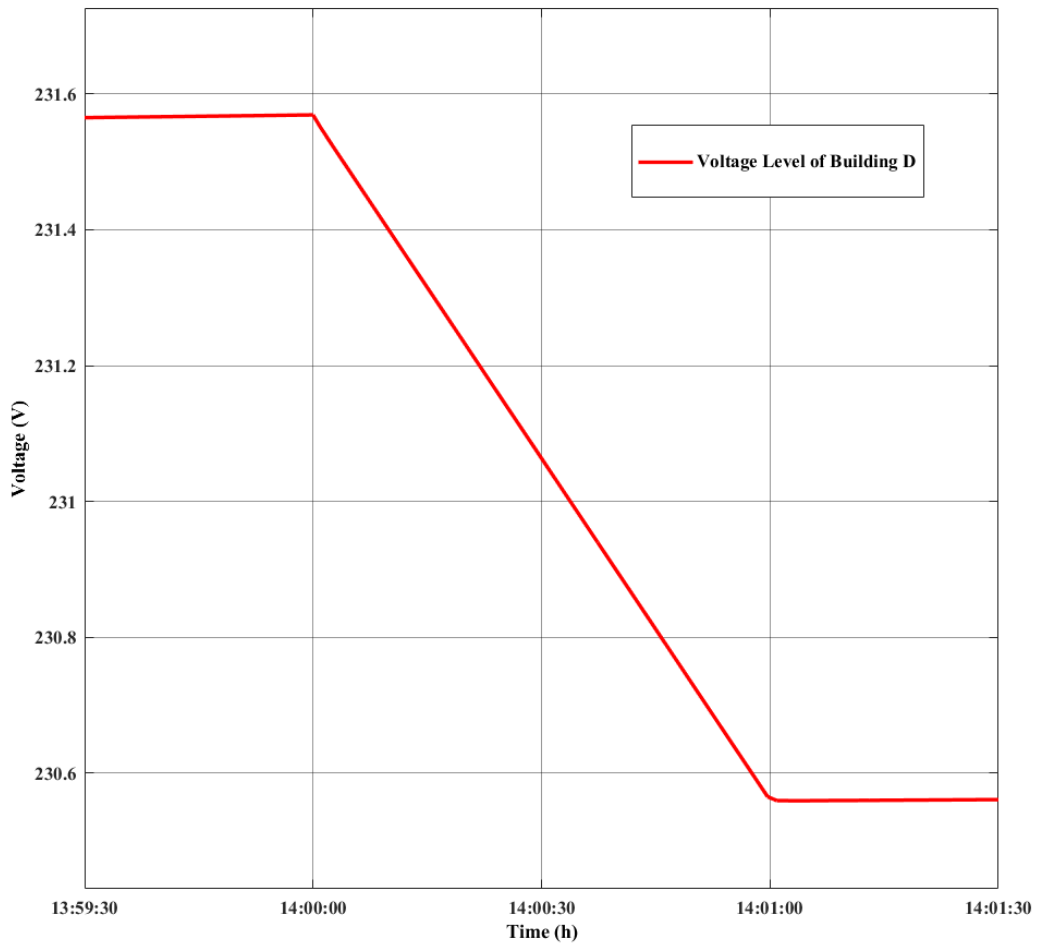

Figure 4.3.3.4.1 20% PV Penetration voltage graph of Building D without BSS

The voltage graph of the Building D for 1 minute when the PV penetration level drops from 100% ($1000 W/m^2$) to 20% ($200 W/m^2$) is given in Figure 4.3.3.4.1. Also, in this case, it is assumed that there is no battery storage system in the Building D. As clearly can be seen from Figure 4.3.3.4.1, while PV power

drops from 21 kW to 4.2 kW, the average voltage level of Building D decreases 1 V in a minute. Although this decreasing is within acceptable limits, deterioration in the voltage quality may cause some serious damage to electronic devices. It is worth mentioning that this voltage level is the average voltage level. When the voltage phases are examined separately, it may be possible to see larger voltage drops.

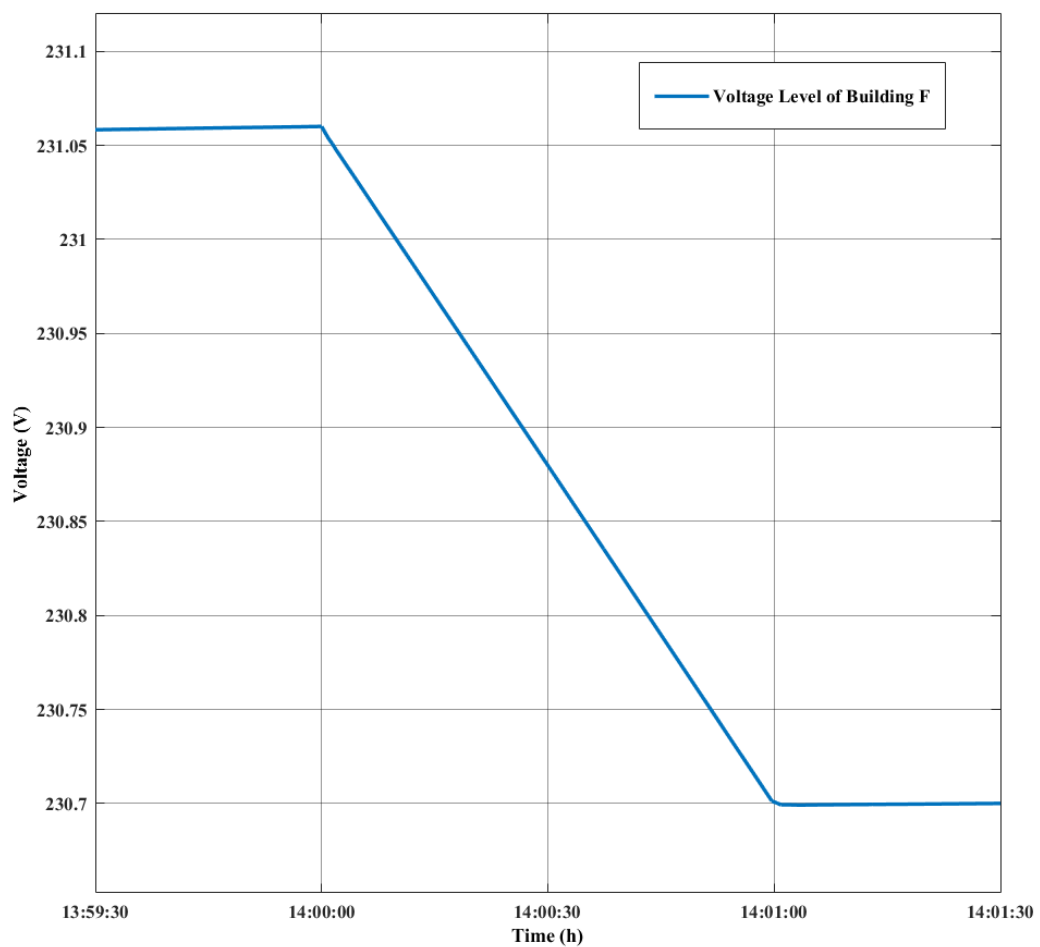

Figure 4.3.3.4.2 20% PV Penetration voltage graph of Building F without BSS

The voltage graph of the Building F for 1 minute when the PV penetration level drops from 100% ($1000 W/m^2$) to 20% ($200 W/m^2$) is given in Figure 4.3.3.4.2. In this case, it is assumed that there is no battery storage system in the Building D. During analyzed interval average voltage level decreases to 230.7 V from 231.06 V between 14:00 and 14:01. Although it is smaller than the

Building D and close to the Building J where the diesel generator is located, the voltage drop of 0.36 V seen in Building F is a warning for situations that may occur if the generator fails to deliver the required performance.

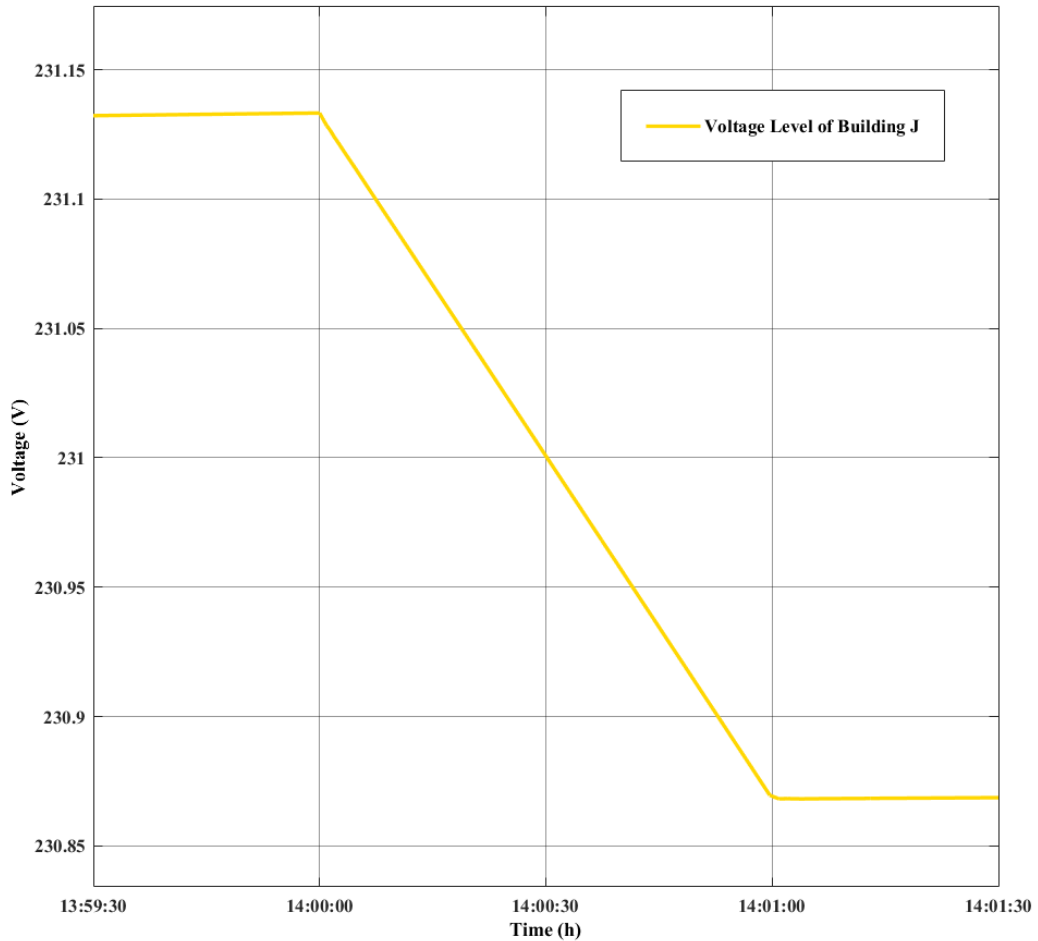

Figure 4.3.3.4.3 20% PV Penetration voltage graph of Building J without BSS

The voltage graph of the Building J for 10 minutes interval when the PV power drops from 100% to 20% is given in Figure 4.3.3.4.3. Also, in this case, it is assumed that there is no battery system in the Building D. As can be seen from the figure, 1 minute after the voltage drop starts, the average voltage levels decline to the lowest value until the diesel generator gives the adequate power to the grid. Before PV power declines to 20% from 100%, the average voltage level is 231.13 V. The lowest voltage level seen during the analyzed time

interval is 230.87 V. Even at 80% power loss, the voltage drop seen in Building J is only 0.26 V.

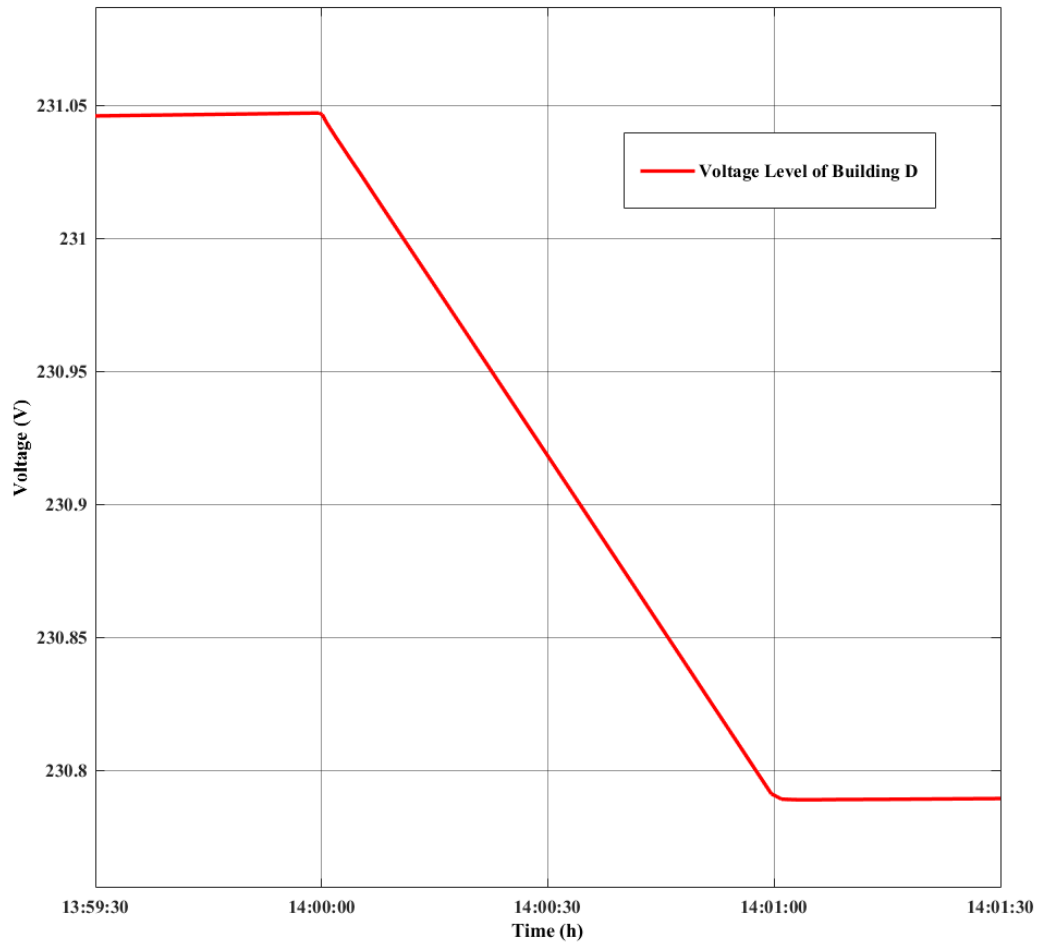

Figure 4.3.3.4.4 20% PV Penetration voltage graph of Building D with BSS

The voltage graph of Building D for the 1-minute interval when the PV power drops from 100% to 20% is given in Figure 4.3.3.4.4. Also, it should be noted, in this case, it is assumed that there is a battery system in the Building D. Average voltage level comes with a stable trend to the analyzed time interval and before the voltage drop happens voltage level of this building is around 231.05 V, and the maximum voltage fluctuation observed during the 1-minute period 0.26 V. It should be remembered that for the same case, when the battery in Building D is removed from the system, observed voltage drop is 1 V, so the presence of the battery makes 0.74 V recovery.

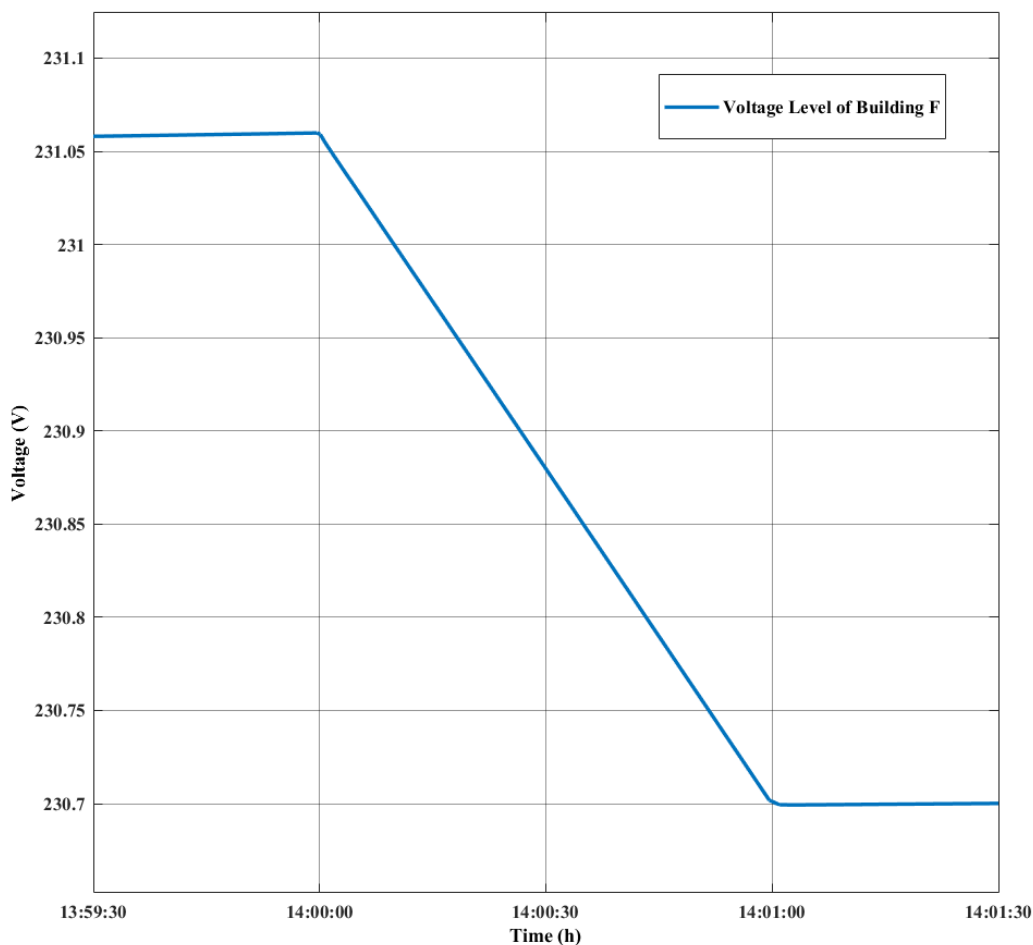

Figure 4.3.3.4.5 20% PV Penetration voltage graph of Building F with BSS

The voltage graph of the Building F for 1 minutes interval when the PV power drops from 100% to 20% is given in Figure 4.3.3.4.5. Also, it should be noted, in this case, it is assumed that there is a battery system in the Building D. As can be seen from the figure, the maximum voltage drop is 0.35 V. We can say that, as in previous cases for Building F, due to support of the powerful diesel generator, 80% drop in PV power does not negatively affect the voltage quality of this buildings. Thus, the use of the 15kW battery system does not make a significant difference for the Building F.

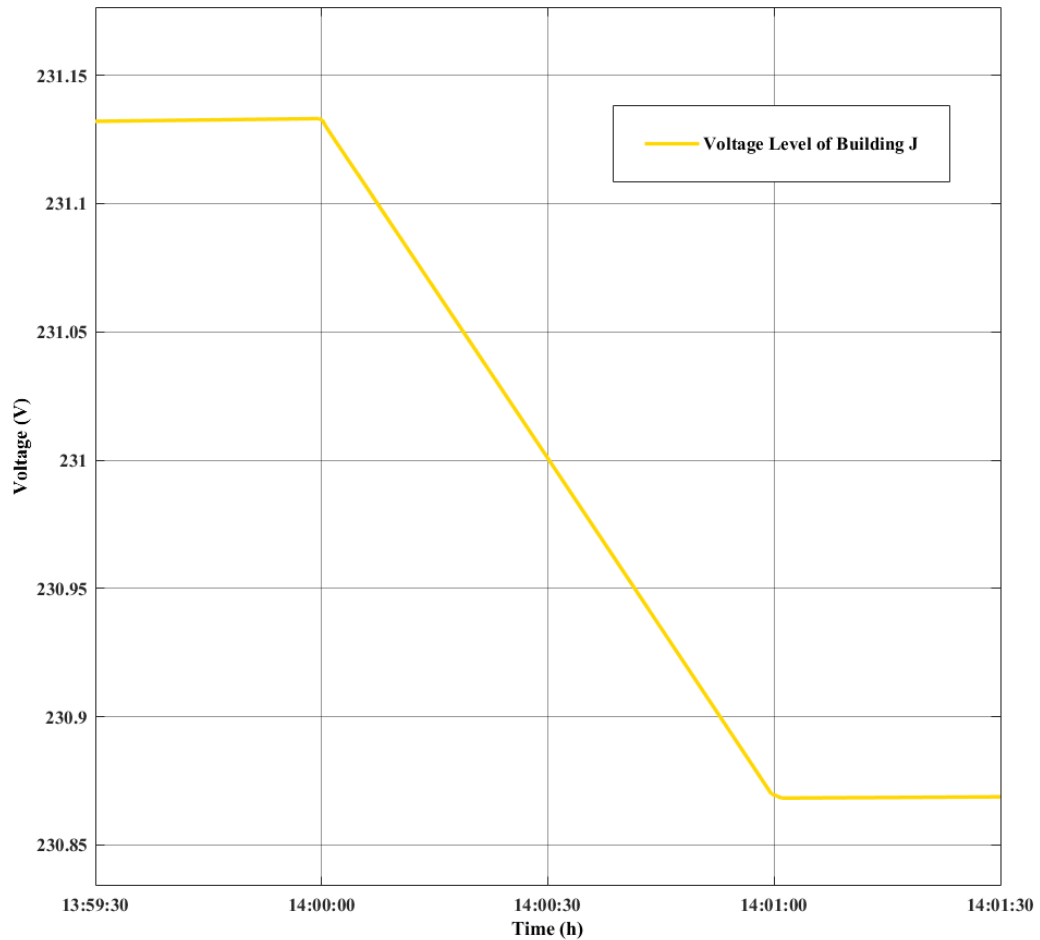

Figure 4.3.3.4.6 20% PV Penetration voltage graph of Building J with BSS

The voltage graph of the Building J for the analyzed 1-minute interval when the PV power drops from 100% to 0% (from 21 kW to 4.2 kW) is given in Figure 4.3.3.4.6. Also, in this case, it is assumed that there is a battery system in the Building D. Until the voltage level reaches a stable profile, voltage of this building decreases to 230.87 V. Therefore voltage drop is 0.26 V for this building. Despite the 80% decline in PV systems, the diesel generator can easily meet the energy requirements of Building J.

To see results more clearly, Figure 4.3.3.4.7 gives the voltage drops in all buildings for the 20% penetration.

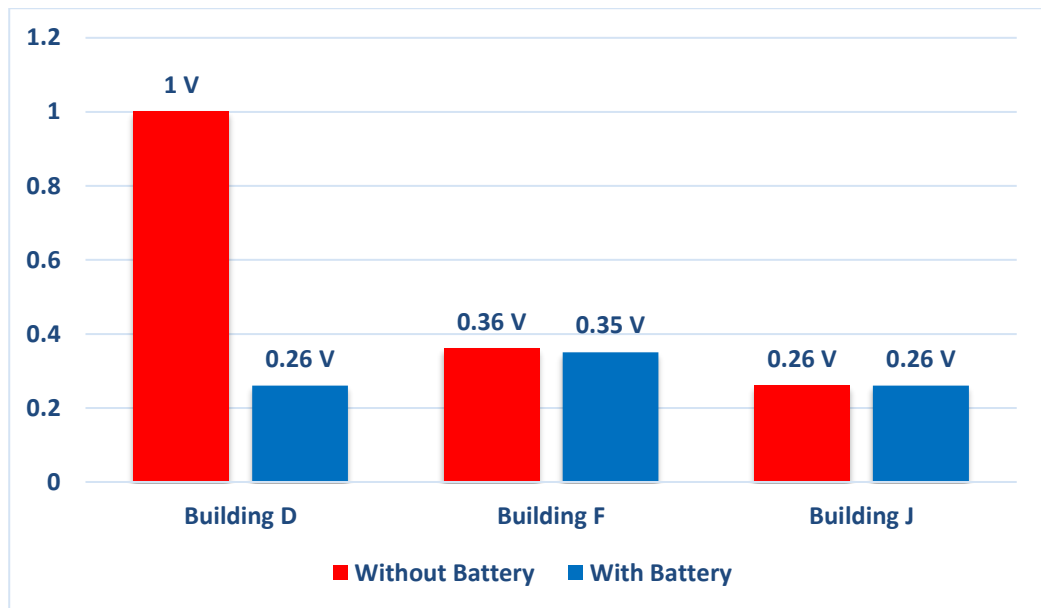

Figure 4.3.3.4.7 Voltage drops in buildings for the 20% penetration level

As a conclusion, as in other cases, the battery system is only able to directly influence the voltage quality of Building D. Building F and J are under the responsibility of diesel generator. No significant voltage fluctuation in previous penetration levels (80%, 60%, 40%) is observed, however, 80% drop (from 100% to 20%) in PV penetration can be dangerous for Building D.

4.4 Voltage Drops for All Cases

The effects of cloud-induced solar radiance interruptions on load voltage levels were investigated in three different main case studies. Battery and non-battery analysis for 0% PV penetration level is done in the base case and case 2. In Case 3, 80%, 60%, 40%, 20% PV penetration levels for either battery and non-battery options are examined in four different subcases, respectively. In this section, results from performed simulations for all cases and all buildings are given in Table 4.4.1.

	Building D		Building F		Building J	
Penetration Levels	<i>Without Battery</i>	<i>With Battery</i>	<i>Without Battery</i>	<i>With Battery</i>	<i>Without Battery</i>	<i>With Battery</i>
0%	1.26 V	0.32 V	0.46 V	0.45 V	0.33 V	0.33 V
20%	1 V	0.26 V	0.36 V	0.35 V	0.26 V	0.26 V
40%	0.75 V	0.19 V	0.27 V	0.26 V	0.2 V	0.2 V
60%	0.5 V	0.13 V	0.18 V	0.17 V	0.13 V	0.13 V
80%	0.24 V	0.06 V	0.09 V	0.08 V	0.06 V	0.06 V

Table 4.4.2 Voltage drops in buildings for all cases

Chapter 5

Conclusions and Future Works

This chapter shares inferences from thirty different simulation results calculated for battery and battery-free conditions at five different PV penetration levels (80%, 60%, 40%, 20%, 0%) for three buildings and presents what can be done to improve the research in future studies.

5.1 Conclusions

In this thesis study, the author investigates the impacts of unbalanced solar power outputs - generated by solar irradiation interrupted by unpredictable cloud movements - on voltage levels of the loads in the microgrid designed for a real field project. As a result of the data obtained, the following comments can be made.

- When the thirty simulation results are examined, there is no voltage drop in violation of the acceptable voltage standards mentioned in the [44] for the microgrid designed for the MCAST campus. However, the voltage standards are general expressions, the durability levels of each electronic device differ. Therefore, voltage loss of 1.26 V that occurs within 1 minute in Building D at 0% penetration level may cause a reduction in voltage quality which could be harmful to customer's devices.
- One of the aims of the thesis study is to examine not only the voltage losses but also the effect of the battery system used in Building D on these voltage losses. Thus, when the results are examined, it can be said that due to powerful diesel generator in Building J the 15 kW battery storage system in the Building D does not have much impact on voltage

profiles of Building F and J, on the contrary, it provides a significant improvement in the voltage quality of Building D.

- As previously mentioned, when microgrid operates in an islanded mode, the diesel generator in the Building J is primarily responsible for providing the power required to ensure that the microgrid operates appropriately. It has clearly shown from the simulation results that the diesel generator in the Building J has ensured the microgrid to continue to run smoothly during periods of PV power drops. The generator prevents the degradation of the voltage quality of Building J and Building F explicitly, but generator has the lesser impact on the voltage quality of Building D as it is the farthest building to the generator and the largest building in the microgrid system. Also, the diesel generator has suppressed the effect of the battery system in Building D to the voltage level of the Building F and Building J.

5.2 Future Works

It can easily be said that the number of microgrids is increasing all over the world and microgrids play an essential role regarding both the economic conditions and the future of our planet. As the number of microgrids increases, the ambiguous behaviors of renewable energy resources, as shown in this study, has a significant impact on the performance of these networks. Many studies are being done to solve such problems. Undoubtedly, the biggest share among these studies belongs to the forecasting studies the possible interruptions in resources such as solar, wind energy, etc. As technologies, such as data mining, artificial intelligence, develop and integrate into networks, there will be significant increases in the accuracy rates and impacts of these forecasting studies, and forecasting techniques will be more successful in preventing the harmful effects of these interruptions.

Efforts to prevent the impacts of the chaotic behaviors of renewable energy resources on small networks such as microgrids should be carried out at the first

planning stages. It is important to consider the historical weather data of the region where microgrid will be established and to choose the appropriate renewable energy resources where the highest yield can be obtained. In addition to many traditional techniques to complete this planning phase, innovative solutions that have taken their place in different disciplines, such as game theory, can be adapted to power system studies. The author aims at minimizing the impact of the interruption problems of renewable energy resources on microgrids by use of game theory techniques for the next stage of this thesis. Finally, if we want the microgrids to offer an entirely innovative solution for our planet, we need to reduce the use of energy sources that are harmful to the environment, such as diesel generators. It will be an essential part of the planning stage in the process of determining the clean resources that can be replaced instead of the environmentally damaging sources, such as a diesel generator.

BIBLIOGRAPHY

- [1] IEA, “2016 SNAPSHOT OF GLOBAL PHOTOVOLTAIC MARKETS.” [Online]. Available: http://www.iea-pvps.org/fileadmin/dam/public/report/statistics/IEA-PVPS_-_A_Snapshot_of_Global_PV_-_1992-2016__1_.pdf. [Accessed: 16-Nov-2018].
- [2] Greentech Media, “Global Solar Capacity Set to Surpass Nuclear for the First Time | Greentech Media.” [Online]. Available: <https://www.greentechmedia.com/articles/read/global-solar-capacity-set-to-surpass-global-nuclear-capacity#gs.XQnVOjw>. [Accessed: 16-Nov-2018].
- [3] Wikipedia, “Growth of Photovoltaics.” [Online]. Available: https://en.wikipedia.org/wiki/Growth_of_photovoltaics. [Accessed: 16-Nov-2018].
- [4] I. Energy Agency, “Technology Roadmap Solar Photovoltaic Energy - 2014 edition.”
- [5] P. Mohammadi and S. Mehraeen, “Challenges of PV Integration in Low-Voltage Secondary Networks,” *IEEE Trans. Power Deliv.*, 2017.
- [6] F. Katiraei and J. R. Agüero, “Solar PV integration challenges,” *IEEE Power Energy Mag.*, 2011.
- [7] R. A. Walling, R. Saint, R. C. Dugan, J. Burke, and L. A. Kojovic, “Summary of distributed resources impact on power delivery systems,” *IEEE Trans. Power Deliv.*, 2008.
- [8] Solar Energy Industries Association, “Solar Market Insight Report 2015 Q1 | SEIA.” [Online]. Available: <https://www.seia.org/research-resources/solar-market-insight-report-2015-q1>. [Accessed: 16-Nov-2018].
- [9] D. Steen *et al.*, *Challenges of Integrating Solar And Wind Into the Electricity Grid.* .
- [10] E. C. Kern and E. M. Gulachenski, “Cloud effects on distributed

- photovoltaic generation: Slow transients at the gardner, massachusetts photovoltaic experiment,” *IEEE Trans. Energy Convers.*, vol. 4, no. 2, pp. 184–190, 1989.
- [11] G. K. Ari and Y. Baghzouz, “Impact of high PV penetration on voltage regulation in electrical distribution systems,” in *3rd International Conference on Clean Electrical Power: Renewable Energy Resources Impact, ICCEP 2011*, 2011, pp. 744–748.
- [12] E. M. Stewart, T. P. Aukai, S. D. J. MacPherson, B. P. Quach, D. Nakafuji, and R. Davis, “A realistic irradiance-based voltage flicker analysis of PV applied to Hawaii distribution feeders,” in *IEEE Power and Energy Society General Meeting*, 2012.
- [13] R. Yan and T. K. Saha, “Investigation of voltage stability for residential customers due to high photovoltaic penetrations,” *IEEE Trans. Power Syst.*, vol. 27, no. 2, pp. 651–662, 2012.
- [14] A. Agrawal, K. Rahimi, R. P. Broadwater, and J. Bank, “Performance of PV generation feedback controllers: Power factor versus Volt-VAR control strategies,” in *2015 North American Power Symposium, NAPS 2015*, 2015.
- [15] D. Cheng, B. A. Mather, R. Seguin, J. Hambrick, and R. P. Broadwater, “Photovoltaic (PV) Impact Assessment for Very High Penetration Levels,” *IEEE Journal of Photovoltaics*, vol. 6, no. 1, pp. 295–300, 2016.
- [16] M. D. K. Rahimi, R. Broadwater, S. Omran, “Quasi-Steady-State computation of voltage flicker with cloud motion simulator,” in *2017 IEEE Power Energy Conf. Illinois, Champaign, IL, USA, 2017*, 2017, pp. 1–8.
- [17] R. Yan and T. K. Saha, “Voltage variation sensitivity analysis for unbalanced distribution networks due to photovoltaic power fluctuations,” *IEEE Trans. Power Syst.*, vol. 27, no. 2, pp. 1078–1089, 2012.
- [18] M. A. Zehir *et al.*, “Impacts of microgrids with renewables on secondary distribution networks,” *Appl. Energy*, vol. 201, pp. 308–319, 2017.
- [19] A. Parchure, S. J. Tyler, M. A. Peskin, K. Rahimi, R. P. Broadwater, and

- M. Dilek, “Investigating PV generation induced voltage volatility for customers sharing a distribution service transformer,” in *IEEE Transactions on Industry Applications*, 2017, vol. 53, no. 1, pp. 71–79.
- [20] A. Woyte, V. Van Thong, R. Belmans, and J. Nijs, “Voltage fluctuations on distribution level introduced by photovoltaic systems,” *IEEE Trans. Energy Convers.*, 2006.
- [21] J. Schnabel, “Compensation of PV Generator Power Fluctuations Using Energy Storage Systems,” 2015.
- [22] J. A. Nelson, “Effects of Cloud-Induced Photovoltaic Power Transients on Power System Protection,” 2010.
- [23] Y. T. Tan and D. S. Kirschen, “Impact on the power system of a large penetration of photovoltaic generation,” in *2007 IEEE Power Engineering Society General Meeting, PES*, 2007.
- [24] V. Cirjaleanu, “Investigation of Cloud-Effects on Voltage Stability of Distribution Grids with Large Amount of Solar Photovoltaics,” 2017.
- [25] M. M. Begovic, I. Kim, D. Novosel, J. R. Aguero, and A. Rohatgi, “Integration of photovoltaic distributed generation in the power distribution grid,” in *Proceedings of the Annual Hawaii International Conference on System Sciences*, 2012.
- [26] R. Yan, S. Roediger, and T. Saha, “Impact of photovoltaic power fluctuations by moving clouds on network voltage: A case study of an urban network,” in *Power Engineering Conference (AUPEC), 2011 21st Australasian Universities*, 2011.
- [27] X. Liang, “Emerging Power Quality Challenges Due to Integration of Renewable Energy Sources,” in *IEEE Transactions on Industry Applications*, 2017, vol. 53, no. 2, pp. 855–866.
- [28] J. Kankiewicz and M. Sengupta, “Observed Impacts of Transient Clouds on Utility-Scale PV Fields,” *ASES Natl. Sol. Conf.*, 2010.
- [29] General Electric, “Yenilenebilir Enerji Kaynakları ve Çe itleri | GE Türkiye Blog.” [Online]. Available: <https://geturkiyeblog.com/yenilenebilir-enerji-kaynaklari-cesitleri/>.

[Accessed: 16-Nov-2018].

- [30] A. N. Mourad, A. A. Elbaset, and H. A. Ziedan, “Challenges of Smart Integration Systems: A Review,” *Int. J. Electron. Electr. Eng.*, vol. 5, no. 1, 2017.
- [31] P. Basak, S. Chowdhury, S. Halder Nee Dey, and S. P. Chowdhury, “A literature review on integration of distributed energy resources in the perspective of control, protection and stability of microgrid,” *Renewable and Sustainable Energy Reviews*. 2012.
- [32] Aselsan, “Mikro ebeke Sistemleri.” [Online]. Available: <http://www.aselsan.com.tr/tr-tr/cozumlerimiz/enerji-sistemleri/enerji-yonetimiveakillisebekesistemleri/mikro-sebeke-sistemleri>. [Accessed: 16-Nov-2018].
- [33] General Microgrids, “generalmicrogrids | About Microgrids.” [Online]. Available: <https://www.generalmicrogrids.com/about-microgrids>. [Accessed: 16-Nov-2018].
- [34] M. Agrawal and A. Mittal, “Micro grid technological activities across the globe: A review,” *Int. J. Res. Rev. Appl. Sci*, 2011.
- [35] Wikipedia, “Microgrid.” [Online]. Available: <https://en.wikipedia.org/wiki/Microgrid>. [Accessed: 16-Nov-2018].
- [36] Microgrid Institute, “About Microgrids - Microgrid Institute.” [Online]. Available: <http://www.microgridinstitute.org/about-microgrids.html>. [Accessed: 16-Nov-2018].
- [37] L. Mariam, M. Basu, M. Conlon, L. Mariam, M. & Basu, and M. F. Conlon, “A review of existing microgrid architectures,” *J. Eng.*, 2013.
- [38] Y. Yolda , A. Onen, S. M. Muyeen, A. V. Vasilakos, and . Alan, “Enhancing smart grid with microgrids: Challenges and opportunities,” *Renew. Sustain. Energy Rev.*, vol. 72, pp. 205–214, 2017.
- [39] N. W. A. Lidula and A. D. Rajapakse, “Microgrids research: A review of experimental microgrids and test systems,” *Renew. Sustain. Energy Rev.*, 2011.
- [40] Department of Energy, “How Microgrids Work | Department of Energy.”

- [Online]. Available: <https://www.energy.gov/articles/how-microgrids-work>. [Accessed: 16-Nov-2018].
- [41] R. Zamora and A. K. Srivastava, "Controls for microgrids with storage: Review, challenges, and research needs," *Renew. Sustain. Energy Rev.*, 2010.
- [42] B. S. Hartono, Budiyanto, and R. Setiabudy, "Review of microgrid technology," in *2013 International Conference on Quality in Research, QiR 2013 - In Conjunction with ICCS 2013: The 2nd International Conference on Civic Space*, 2013.
- [43] 3DMicrogrid, "3DMicroGrid Overview." [Online]. Available: <http://www.3dmicrogrid.com/overview.html>. [Accessed: 16-Nov-2018].
- [44] Energypedia, "Permissible Voltage Drop - energypedia.info." [Online]. Available: https://energypedia.info/wiki/Permissible_Voltage_Drop. [Accessed: 27-May-2018].